



SHANGHAI DETALL ELECTRONICS TECHNOLOGY



SHANGHAI DETALL ELECTRONICS TECHNOLOGY

OFFICE ADD: ROOM 326, NO.2525, Chunshen Rd, Minhang , Shanghai China, 201104.

Factory ADD: Wei 12th Road, Huaining Industrial Park, Anging, Anhui, China

TEL : +86-21-64765807 Mob:+86-17701726391

Email: Sales@detall-esd.com Web: www.detall-esd.com

**SPECIALIZED IN
WORKSPACE AND STORAGE SOLUTIONS**

Make your work more efficient and comfortable.

CONTENT

Workbench	01
1 Standard Workbench	
2 Light duty workbench	
3 Heavy duty 4 foot workbench	
4 Tower-line workbench	
6 Packing table	
7 Hydraulic height adjustment workbench	
Workbench accessories	15
Table tops	30
Conveyor	31
Expandable conveyor	
Belt conveyor	
Roller conveyor	
Accumulating roller chain conveyor	
Accumulating free roller conveyor	
Trolley	43
Silent hand trolley	
Antistatic trolley	
Water Activated Tape Dispenser	46
Paper void filler	47
Bubble Paper filling machine	48
Wire shelf cart	49
Tool cabinet	51
Electronic Moisture-proof Cabinet	53
Fireproof Cabinet	58
Shelves	59
ESD shelves	
FIFO shelves	
Heavy duty shelves	
Heavy duty pallet shelves	
Table mat & Floor mat	61
ESD table mat	
ESD foamed mat	
ESD fire-resistant floor mat	
ESD anti-fatigue floor mat	
ESD PVC Plastic Tile	
Soldering Fume Purifier	63
Task Chair	65
Ionizing Air Blower	69
Comprehensive Tester	70
Lead-free Soldering Station	72
Hooks	74

COMPANY PROFILE

Detail is a professional supplier of industrial furniture and automation equipment, headquartered in Shanghai. Since 2005, it has developed from designing and manufacturing ESD Workbench to now being able to design and provide a large number of automated assembly equipment. Relying on leading designs, competitive prices and excellent quality, Detail has expanded its products and markets to every corner of the world.

Our commitment to quality extends beyond our products to include exceptional customer service and support. Detail's experienced designers, patient and enthusiastic sales staff are always ready to provide you with satisfactory designs and services, fast and accurate production equipment can provide flexible customized products. Customer satisfaction is the only standard for our team.



OUR CUSTOMER



●Structure features



- ※ Product structure and accessories are all modular.
- ※ Features modular accessories that cover most bench functions.
- ※ Functional accessories all have quick disassembly and installation structures.
- ※ It can freely configure a workbench with various functions according to the needs of the user.

●Size



M structure (Length1200mm) 2M structure (Length1530/1830mm) 3M structure (Length2280mm)

- ※ Standard length: 1200/1530/1830/2280mm ; Standard depth:600/750/900mm
- ※ Various custom sizes available

●ESD performance

EN 61340-5-1:2016	Working surfaces, storage racks and trolley	< 1×10 ⁹ Ω
IEC 61340-5-1:2016	Working surfaces, storage racks and trolley	< 1×10 ⁹ Ω
TEST	Relative Humidity	Electrical Results
Point to point resistance	60%-40%	1 x 10 ⁵ - 1 x 10 ⁹ Ω
	40%-20%	1 x 10 ⁵ - 1 x 10 ⁹ Ω
	20%-10%	1 x 10 ⁷ - 1 x 10 ⁹ Ω
Point to earth resistance	60%-40%	1 x 10 ⁵ - 1 x 10 ⁹ Ω
	40%-20%	1 x 10 ⁵ - 1 x 10 ⁹ Ω
	20%-10%	1 x 10 ⁷ - 1 x 10 ⁹ Ω
Volume Resistance	60%-40%	10 ⁷ to 1 x 10 ⁹ Ω
	40%-20%	10 ⁷ to 1 x 10 ⁹ Ω

1 Standard Workbench



Standard workbench series & specification

Standard workbench – Height Non-adjustable	Table top height 760mm	Uniform static load 500kg
Standard workbench – manual screw adjustment	Table top height 670-1120mm	Uniform static load 500kg
Standard workbench – hand crank adjustment	Table top height 720-1020mm	Uniform static load 250kg
Standard workbench – motorized adjustment	Table top height 725-1070mm	Uniform static load 100kg
Standard workbench – heavy duty motorized adjustment	Table top height 720-1100mm	Uniform static load 600kg



1.1 Standard Workbench – Height Non-adjustable



- ※ Height 760mm
- ※ Uniform static load 500KG
- ※ **Available size:**
Length: 1200/1530/1830/2280mm
Depth: 600/750/900mm

1.2 Standard Workbench – Manual Screw Adjustment



- ※ Height 670-1120mm · Height adjustable by screws manually
- ※ Uniform static load 500KG
- ※ **Available size:**
Length: 1200/1530/1830/2280mm
Depth: 600/750/900mm



Config NO. DTA201
Table top size | 1530×750mm



Config NO. DTA202
Table top size | 1530×750mm



Config NO. DTA116
Table top size | 1830×750mm



Config NO. DTA108
Table top size | 1530×750mm



Config NO. DTA115
Table top size | 1530×750mm



Config NO. DTA101
Table top size | 1200×600mm



Config NO. DTA204
Table top size | 1530×750mm



Config NO. DTA205
Table top size | 1530×900mm



Config NO. DTA103
Table top size | 2280×750mm



Config NO. DTA206
Table top size | 1530×750mm



Config NO. DTA207
Table top size | 1530×750mm



Config NO. DTA208
Table top size | 1530×750mm

1.3 Standard Workbench – Hand Crank Adjustment



- ※ Height 720-1020mm, height adjustable by hand crank
- ※ Uniform static load 250KG
Uniform dynamic load 150KG, Lift 3mm/ revolution
- ※ Available size:
Length: 1200/1530/1830mm
Depth: 600/750/900mm
- ※ Reduce desktop load to less than 150kg when adjusting height to extend service life.



1.4 Standard Workbench – Motorized Adjustment



- ✧ Height 725-1070mm, height adjustable by electric motor
- ✧ Uniform static load 100KG
Uniform dynamic load 100KG, Lift 30mm/s
- ✧ **Available size:**
Length: 1200/1530/1830mm
Depth: 600/750/900mm
- ✧ LED digital display controller, button adjustment, can display and memorize 4 height values. Press the Memory Height key once to automatically adjust to the memory height.
- ✧ Electric motors are CE and UL certified
- ✧ Reduce desktop load to less than 100kg when adjusting height to extend service life.



Config NO. DTA219
Table top size | 1530x750mm



Config NO. DTA220
Table top size | 1530x750mm



Config NO. DTA221
Table top size | 1530x750mm



Config NO. DTA222
Table top size | 1830x750mm



Config NO. DTA223
Table top size | 1530x750mm



Config NO. DTA224
Table top size | 1530x750mm

1.5 Standard Workbench – Heavy Duty Motorized Adjustment



- ✧ Height 720-1100mm, height adjustable by electric motor
- ✧ Uniform static load 600KG
Uniform dynamic load 500KG, Lift 15mm/s
- ✧ **Available size:**
Length: 1200/1530/1830mm
Depth: 600/750/900mm
- ✧ LED digital display controller, button adjustment, can display and memorize 4 height values. Press the Memory Height key once to automatically adjust to the memory height.
- ✧ Electric motors are CE and UL certified
- ✧ Reduce desktop load to less than 500kg when adjusting height to extend service life.



Config NO. DTA225
Table top size | 1530x750mm



Config NO. DTA226
Table top size | 1530x750mm



Config NO. DTA218
Table top size | 1530x750mm

2 Light duty workbench



- ※ Height 760mm
- ※ Uniform static load 300KG
- ※ **Available size:**
Length: 1200/1530/1830mm
Depth: 600/750/900mm



Config NO. DTA227

Table top size 1200×750mm



Config NO. DTA228

Table top size 1200×600mm



Config NO. DTA229

Table top size 1530×750mm



Config NO. DTA230

Table top size 1530×750mm



Config NO. DTA231

Table top size 1530×750mm



Config NO. DTA232

Table top size 1530×750mm

3 Heavy duty 4 foot workbench



- ※ Non-Height-adjustable 785mm
- ※ Height adjustable 745-1015mm
- ※ Uniform static load 1000KG
- ※ **Available size:**
Length: 1200/1530/1830/2280mm
Depth: 600/750/900mm



Config NO. DTA120

Table top size 1200×750mm



Config NO. DTA124

Table top size 1530×750mm



Config NO. DTA233

Table top size 1830×750mm



Config NO. DTA234

Table top size 2280×750mm



Config NO. DTA235

Table top size 1530×750mm+560×750mm

4 Tower-line workbench



- ✘ Slotted upright frame integrated into the table stand structure
- ✘ Easy and cheap to extend side by side & face to face
- ✘ Uniform static load 300KG
- ✘ Available size:
Column internal width: 1200/1530/1830mm
Tabletop Depth: 600/750mm



6 Packing table



- ※ Height 670-1120mm, height adjustable by screws
- ※ Uniform static load 500KG, Uniform dynamic load 300KG
- ※ **Available size:**
Length: 1550/1850mm
Depth: 650/700/750mm



Config NO. DTA241
Table top size 1550×750mm



Config NO. DTA242
Table top size 1550×750mm



Config NO. DTA155
Table top size 1550×750mm



Config NO. DTA243
Table top size 1550×750mm



Config NO. DTA244
Table top size 1550×750mm



Config NO. DTA245
size 1550×750+450×755mm



Config NO. DTA156
Table top size 1550×750mm



Config NO. DTA157
Table top size 1550×750mm



Config NO. DTA246
Table top size 1600×750mm+1600×500mm



Config NO. DTA249

7 Hydraulic height adjustment workbench

Manual hydraulic height adjustment, load 1000kgs.
Easy to move, wide use scenarios, not limited by power supply



Config NO. DTA247
Table top size 1200×900mm



Config NO. DTA158
Table top size D=900mm



Config NO. DTA248
Table top size 1000×1000mm

M750 model of accessories are suitable for M750, 2M750 and 3M750 Upright Frame

M900 model of accessories are suitable for M900 and 2M900 Upright Frame

M1200 model of accessories are suitable for M1200 Upright Frame

M1530 model of accessories are suitable for 2M750, M1530 and 3M750 Upright Frame

M1830 model of accessories are suitable for 2M900 and M1830 Upright Frame



M Upright Frame			
For mounting accessories to workbench (ESD)			
	Height / Effective height (Height above the table top)		
	1070 series / 784mm	1359 series / 1073mm	1600 series / 1314mm
Type / Width	Part NO.		
M750/780mm	DTL1M7510	DTL1M7513	DTL1M7516
M900/930mm	DTL1M9010	DTL1M9013	DTL1M9016
M1200/1200mm	DTL1M1210	DTL1M1213	DTL1M1216
M1530/1530mm	DTL1M1510	DTL1M1513	DTL1M1516
M1830/1830mm	DTL1M1810	DTL1M1813	DTL1M1816



2M Upright Frame			
For mounting accessories to workbench (ESD)			
	Height / Effective height (Height above the table top)		
	1070 series / 784mm	1359 series / 1073mm	1600 series / 1314mm
Type / Width	Part NO.		
2M750/1530mm	DTL2M1510	DTL2M1513	DTL2M1516
2M900/1830mm	DTL2M1810	DTL2M1813	DTL2M1816



3M Upright Frame			
For mounting accessories to workbench (ESD)			
	Height / Effective height (Height above the table top)		
	1070 series / 784mm	1359 series / 1073mm	1600 series / 1314mm
Type / Width	Part NO.		
3M750/2280mm	DTL3M1510	DTL3M1513	DTL3M1516



Back Panel	
Mount on upright frame; (ESD)	
Gray and Blue color are available	
Part NO.	Model / Size (W×H mm)
DTB107520	M750 / 741×240
DTB109020	M900 / 891×240
DTB112020	M1200 / 1161×240
DTB107530	M750 / 741×390
DTB109030	M900 / 891×390
DTB112030	M1200 / 1161×390



Documents panel	
Mount on upright frame; (ESD)	
Gray and Blue color are available;	
Part NO.	Model / Size (W×H mm)
DTB307520	M750 / 741×240
DTB309020	M900 / 891×240
DTB312020	M1200 / 1161×240
DTB307530	M750 / 741×390
DTB309030	M900 / 891×390
DTB312030	M1200 / 1161×390

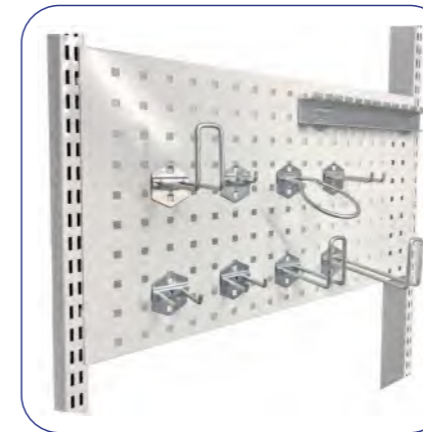

Perforated panel	
Mount on upright frame, For tool hooks; (ESD)	
Gray and Blue color are available; Perforation 10×10mm	
Part NO.	Model / Size (W×H mm)
DTB407520	M750 / 741×240
DTB409020	M900 / 891×240
DTB412020	M1200 / 1161×240
DTB407530	M750 / 741×390
DTB409030	M900 / 891×390
DTB412030	M1200 / 1161×390

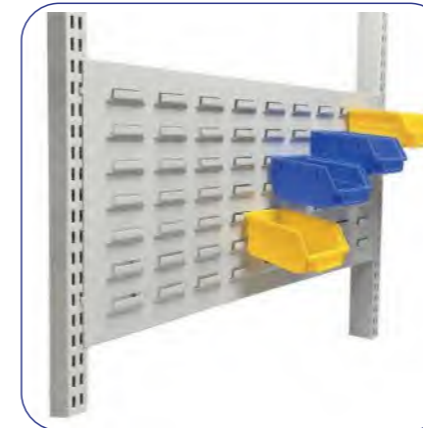

Louvres panel	
Mount on upright frame; For hanging bins; (ESD)	
Gray and Blue color are available; Enhanced hooks	
Part NO.	Model / Size (W×H mm)
DTB507520	M750 / 741×240
DTB509020	M900 / 891×240
DTB512020	M1200 / 1161×240
DTB507530	M750 / 741×390
DTB509030	M900 / 891×390
DTB512030	M1200 / 1161×390



Display hanging panel

Mount on upright frame; For fixing display; (ESD)

Gray and Blue color are available; 75-100mm fixing holes.

Part NO.	Model / Size (W×H mm)
DTB607520	M750 / 741×240
DTB609020	M900 / 891×240
DTB612020	M1200 / 1161×240
DTB607530	M750 / 741×390
DTB609030	M900 / 891×390
DTB612030	M1200 / 1161×390



Perforated + Louvres panel

Mount on upright frame, For tool hooks and bins; (ESD)

Gray and Blue color are available;

Part NO.	Model / Size (W×H mm)
DTB707520	M750 / 741×240
DTB709020	M900 / 891×240
DTB712020	M1200 / 1161×240
DTB707530	M750 / 741×390
DTB709030	M900 / 891×390
DTB712030	M1200 / 1161×390
DTB715030	M1530 / 1491×390
DTB718030	M1830 / 1791×390



Perforated + Bin rial panel

Mount on upright frame, For tool hooks and bins; (ESD)

Gray and Blue color are available; perforation 10×10mm

Part NO.	Model / Size (W×H mm)
DTB807520	M750 / 741×240
DTB809020	M900 / 891×240
DTB812020	M1200 / 1161×240
DTB815020	M1530 / 1491×240
DTB818020	M1830 / 1791×240



Steel Shelf

Mount on upright frame, 30kgs loading; (ESD)

Horizontal installation or 20 degree slant installation

Part NO.	Model / Size (W×H mm)
DTU107530	M750 / 745×306
DTU109030	M900 / 895×306
DTU112030	M1200 / 1165×306
DTU107540	M750 / 745×406
DTU109040	M900 / 895×406
DTU112040	M1200 / 1165×406



Laminate Shelf

Mount on upright frame, 50kgs loading; (ESD)

Part NO.	Model / Size (W×H mm)
DTU207540	M750 / 780×380
DTU209040	M900 / 930×380
DTU212040	M1200 / 1200×380
DTU215040	M1530 / 1530×380
DTU218040	M1830 / 1830×380
DTU222840	M2280 / 2280×380



Adjustable Steel shelf

Mount on upright frame (ESD)

Gray and Blue color are available, 50kgs loading with 2 brackets ;100kgs weight loading with 4 brackets, Angle adjustable

Part NO.	Model / Size (W×D mm)
DTU307505	M750 / 719×649(Bracket×2)
DTU309005	M900 / 869×649(Bracket×2)
DTU312005	M1200 / 1139×649(Bracket×2)
DTU307510	M750 / 719×649 (Bracket×4)
DTU309010	M900 / 869×649(Bracket×4)
DTU312010	M1200 / 1139×649(Bracket×4)



Divider Plate

Use on steel shelf or laminate shelf; (ESD)

For classifying of documents

Part NO.	Size H×D(mm)
DTU400030	190×250
DTU400040	190×350
DTU400041	190×350(For ESD laminated shelf)



Steel Shelf + Divider Tube U1

Mount on upright frame

For classifying or storage of packing cartons U1 Divider size H×D 380×360mm

Part NO.	Model / Size (W×D mm)
DTU507530	M750 / 741.5×380 (3 dividers)
DTU509030	M900 / 891.5×380 (4 dividers)
DTU512030	M1200 / 1161.5×380 (5 dividers)
DTU515030	M1530 / 1491.5×380 (6 dividers)
DTU518030	M1830 / 1791.5×380 (7 dividers)



Steel Shelf + Divider Tube U2	
Mount on upright frame	
For classifying or storage of packing cartons U2 Divider size HxD 380x360mm; For small cartons	
Part NO.	Model / Size (WxD mm)
DTU607530	M750 / 741.5x380 (3 dividers)
DTU609030	M900 / 891.5x380 (4 dividers)
DTU612030	M1200 / 1161.5x380 (5 dividers)
DTU615030	M1530 / 1491.5x380 (6 dividers)
DTU618030	M1830 / 1791.5x380 (7 dividers)

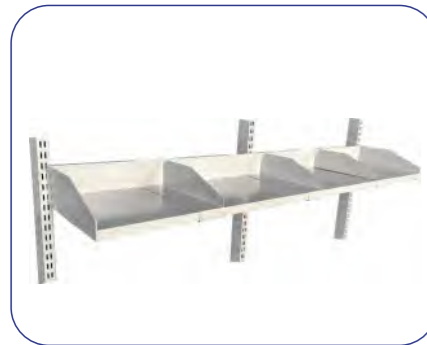

Fenced steel upper shelf	
Mount on upright frame	
For classifying or storage of small parts	
Part NO.	Model / Size (WxD mm)
DTU715030	M1530 / 1491.5x300 (3 dividers)
DTU718030	M1830 / 1791.5x300 (4 dividers)



Adjustable shelf with label rail	
Mount on upright frame, with plastic label rail; (ESD)	
Gray and Blue color are available;	
Part NO.	Model / Size (WxD mm)
DTU810753	M750 / 741x300
DTU810903	M900 / 891x300
DTU811203	M1200 / 1161x300
DTU811503	M1530 / 741x300
DTU811803	M1830 / 891x300
DTU810754	M750 / 741x400
DTU810904	M900 / 891x400
DTU811204	M1200 / 1161x400
DTU811504	M1530 / 741x400
DTU811804	M1830 / 891x400

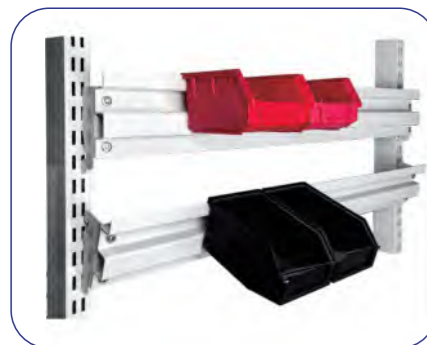

Bin Rail	
Mount on upright frame. For hanging bins; (ESD)	
Horizontal installation or 20 degree tilt installation; 20kgs weight loading	
Part NO.	Model / Size (W mm)
DTR107500	M750 / 742
DTR109000	M900 / 892
DTR112000	M1200 / 1162



Steel shelf under top	
Mount under the table top, For storage; (ESD)	
Gray and Blue color are available;	
Part NO.	Model / Size (WxD mm)
DUU120040	M1200 / 892x400
DUU153040	M1530 / 1162x400
DUU183040	M1830 / 1492x400
DUU228040	M2280 / 1792x400
DUU120060	M1200 / 892x600
DUU153060	M1530 / 1162x600
DUU183060	M1830 / 1492x600
DUU228060	M2280 / 1792x600



Key board Tray	
Fixed under table top.	
5kgs weight loading	
Part NO.	Size LxD(mm)
DTC100001	546*275*85



Multi-adjustable Key board Tray	
Fixed under table top.	
10kgs weight loading; Angle, depth, height adjustable	
Part NO.	Size LxD (mm)
DTC100002	640x230



Floor type computer host holder	
Place on the floor	
Width adjustable, 30kgs weight loading (ESD)	
Part NO.	Size LxD(mm)
DTC200001	400*(130-210)



Hanging type computer host holder	
Fixed on L feet	
Width adjustable, 15kgs weight loading (ESD)	
Part NO.	Size LxD(mm)
DTC200002	400*(180-225)

WORKBENCH ACCESSORIES



Laminated wood foot rest	
50kgs Weight loading; (ESD)	
Part NO.	Size L×D(mm)
DTC300001	500*350



Adjustable steel foot rest	
30kgs Weight loading; (ESD)	
Part NO.	Size L×D(mm)
DTC300002	550*350mm



Sliding Pallet under top	
20kgs weight loading (ESD)	
Part NO.	Size W×D×H (mm)
DTC400001	480×510×500



Swivel display rack	
Mounting on the upright frame	
10kgs loading; (ESD)	
Part NO.	Size W×D(mm)
DTG104050	Display fixing holes 75×75 -100×100mm



Swivel & lifting display rack	
Mounting on the upright frame	
12kgs loading, adaptive hovering	
Part NO.	Size W×L(mm)
DTG206002	Display fixing holes 75×75 – 100×100mm



Swivel display rack + keyboard tray	
Mounting on the upright frame (ESD)	
10kgs loading;	
Part NO.	Size W×D(mm)
DTG106070	Display fixing holes 75×75 -100×100mm Key board tray 600×178

WORKBENCH ACCESSORIES



Swivel & lifting display rack + keyboard tray	
Mounting on the upright frame	
12kgs loading, adaptive hovering	
Part NO.	Size W×L(mm)
DTG206070	Display fixing holes 75×75 – 100×100mm



Swivel & lifting rack – for laptop and tablet	
Mounting on the upright frame	
12kgs loading, adaptive hovering	
Part NO.	Size W×D(mm)
DTG206003	300-420×281mm; Suitable for 10-17 inch laptop or tablet.

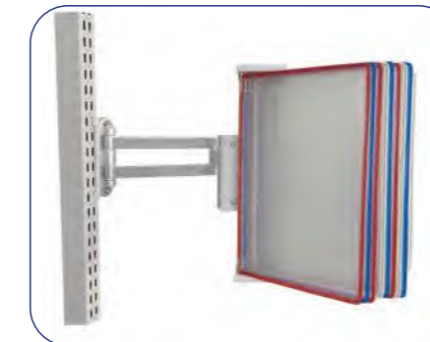

Swivel loose-leaf folder	
Mounting on the upright frame	
Part NO.	Specification
DTG303005	A3 Page 5
DTG303010	A3 Page 10
DTG304005	A4 Page 5
DTG304010	A4 Page 10



Swivel tool plate	
Mounting on the upright frame	
Perforation 10×10mm, 10kgs loading (ESD)	
Part NO.	Size W×H(mm)
DTG403030	290×325



Swivel bin cabinet	
Mounting on the upright frame (ESD)	
10kgs loading	
Part NO.	Size W×D×H(mm)
DTG505183	530×181×353

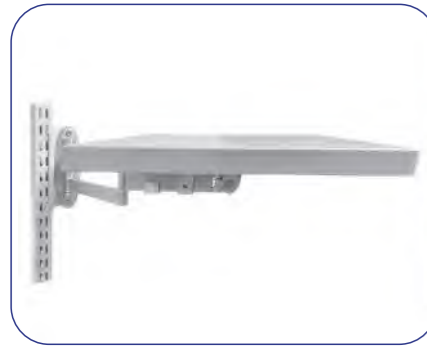

Swivel auxiliary side top	
Mounting on the upright frame (ESD)	
10kgs loading	
Part NO.	Size W×D(mm)
DTG604050	350*400



Fixed auxiliary side top	
ESD Laminated board. Mounting on the upright frame (ESD)	
15kgs loading	
Part NO.	Size W×D (mm)
DTG604550	450×500mm



Sliding auxiliary side top	
Steel, Mounting on the upright frame (ESD)	
15kgs loading	
Part NO.	Size W×D (mm)
DTG604055	400×450



Swivel Bin rack	
Mounting on the upright frame (ESD)	
10kgs loading;	
Part NO.	Specification
DTG706070	424×168mm: 8 pcs bin can be placed (HB1-S, EB2-S)



Swivel roll material rack	
Mounting on the upright frame	
10kgs loading;	
Part NO.	Specification
DTG800001	∅200-H300



Suspension Cabinet SCB-1	
Mounting on the upright frame (ESD)	
50kgs loading; 2 shelves	
Part NO.	Model / Size W×D×H (mm)
DCB107590	M750 / 734×255×900
DCB109090	M900 / 884×255×900

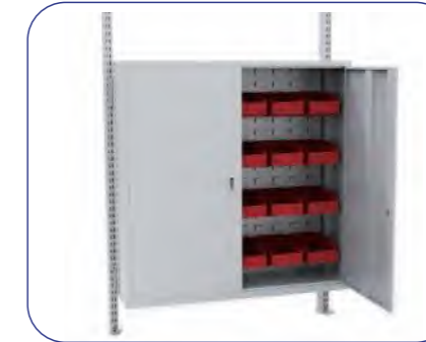

Suspension Cabinet SCB-2	
Mounting on the upright frame (ESD)	
50kgs loading; Louvres back	
Part NO.	Model / Size W×D×H (mm)
DCB207590	M750 / 734×255×900
DCB209090	M900 / 884×255×900



Suspension Cabinet SCB-3	
Mounting on the upright frame (ESD)	
50kgs loading; 2 shelves; perforated doors	
Part NO.	Model / Size W×D×H (mm)
DCB307590	M750 / 734×255×900
DCB309090	M900 / 884×255×900



Suspension Cabinet SCB-4	
Mounting on the upright frame (ESD)	
50kgs loading; 2 shelves Perforated back	
Part NO.	Model / Size W×D×H (mm)
DCB407590	M750 / 734×255×900
DCB409090	M900 / 884×255×900



Suspension Cabinet SCB-5	
Mounting on the upright frame (ESD)	
50kgs loading; 1 shelf	
Part NO.	Model / Size W×D×H (mm)
DCB512040	M1200 / 1155×400×400
DCB515040	M1530 / 1485×400×400
DCB518040	M1830 / 1785×400×400

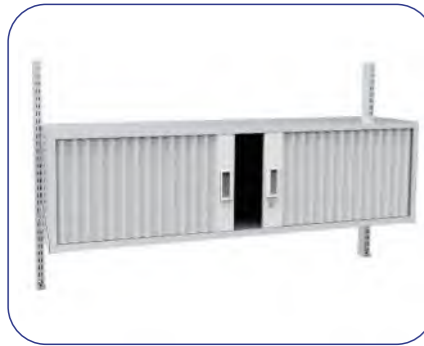

Suspension Cabinet SCB-6	
Mounting on the upright frame (ESD)	
50kgs loading; Roller shutter door	
Part NO.	Model / Size W×D×H (mm)
DCB612040	M1200 / 1155×440×400
DCB615040	M1530 / 1485×440×400 (4 door)
DCB618040	M1830 / 1785×440×400 (4 door)



Suspension drawer- single	
Install under table top (ESD)	
Optional drawer dividers are available; 35kg loading,	
Part NO.	Size W×D×H(mm)
DTD100001	370×486×195
Each Drawer height 150mm	



Suspension drawer - double	
Install under table top (ESD)	
Optional drawer dividers are available: 35kg loading,	
Part NO.	Size W×D×H(mm)
DTD100002	370×486×346
Each Drawer height 150mm	



Suspension drawer - triple	
Install under table top (ESD)	
Optional drawer dividers are available;35kg loading,	
Part NO.	Size W×D×H(mm)
DTD100003	370×486×500
Each Drawer height 150mm	



Suspension drawer cabinet	
35kg loading, (ESD)	
Optional dividers are available	
Part NO.	Size W×D×H(mm)
DTD100004	370×486×500
Drawer H150mm; door H310mm	



Drawer Divider	
Part NO.	Size W×H(mm)
DTD100005	Longitudinal partition D1 438×81mm
DTD100006	Lateral partition D2 154×79mm(Half width)
DTD100007	Lateral partition D3 313×79mm(Full width)



Heavy duty suspension drawer - single	
50kg loading,	
Optional dividers are available	
Part NO.	Size W×D×H(mm)
DTD200001	411×572×180



Heavy duty suspension drawer - double	
50kg loading,	
Optional dividers are available	
Part NO.	Size W×D×H(mm)
DTD200002	411×572×280



Heavy duty suspension drawer - triple	
50kg loading,	
Optional dividers are available	
Part NO.	Size W×D×H(mm)
DTD200003	411×572×380



Movable drawer cabinet Mv2	
35kg loading, (ESD)	
Optional dividers are available	
Part NO.	Size W×D×H(mm)
DTD300001	370×585×590
Drawer height 150mm×3	

WORKBENCH ACCESSORIES



Movable drawer cabinet Mv3

35kg loading, (ESD)

Optional dividers are available

Part NO.	Size W×D×H(mm)
DTD300002	370×585×670 Drawer height 125×2 / 285×1



Slant Light bracket

Mount on upright frame; 30kg weight loading, (ESD)

Part NO.	Model / Size W×D×H (mm)
DTJ1M1200	M1200 / 1182×604×382
DTJ1M1530	M1530 / 1512×604×382
DTJ1M1830	M1830 / 1812×604×382
DTJ1M2280	M2280 / 2262×604×382



Right-angled Light bracket

Mount on upright frame; 30kg weight loading, (ESD)

Part NO.	Model / Size W×D×H (mm)
DTJ2M1200	M1200 / 1190×513×135
DTJ2M1530	M1530 / 1520×513×135
DTJ2M1830	M1830 / 1820×513×135
DTJ2M2280	M2280 / 2270×513×135



Spring Balancer

Used for suspension, concentration, handling and moving tools, fixtures, workpiece etc.

Part NO.	Specification
DTJ100003	Loading 1.5-3.0 kg
DTJ100004	Loading 3.0-5.0 kg



LED light

Fixed on light bracket or upper shelf;

Part NO.	Size W×D×H(mm)
DTJ200001	600MM; 30W; C110-270V; 50/60Hz; White 5000K
DTJ200002	900MM; 40W; C110-270V; 50/60Hz; White 5000K
DTJ200003	1200MM; 40W; C110-270V; 50/60Hz; White 5000K

WORKBENCH ACCESSORIES



LED Magnifying Lamp

Clip on table tops

Part NO.	Specification
DTJ300001	190×50×1138mm Optical green glass; Magnification: 8×; 127mm lens; With dust cover; Light source: 60 LED lamp beads; Brightness adjustable; Input voltage: 100-240V, 50Hz/60Hz; 12 W



Cable Ducts

Mount on upright frame, (ESD)

For covering the cables at the bench back.

Part NO.	Size W×H(mm)
DTF107520	741×290
DTF109020	891×290
DTF112020	1161×290



Power Rail

Mount on upright frame,

Can integrate a variety of standard sockets, network port sockets, pneumatic interfaces, voltage and amp meters, DC sockets, grounded sockets etc.

Part NO.	(Max Qty of sockets)
DTP10M750	M750 (4)
DTP10M900	M900 (5)
DTP1M1200	M1200 (6)
DTP12M750	2M750 (8)
DTP12M900	2M900 (10)
DTP13M750	3M750 (12)



Packing table under shelf

Use on packing table

For classifying or storage of packing cartons U3 Divider size H×D 300×648mm

Part NO.	Size L×D(mm)
DPP115060	1420×668 (3 dividers)
DPP118060	1720×668 (4 dividers)



Divider Cart	
For classifying or storage of packing cartons	
U1 Divider size HxD 380x360mm	
Part NO.	Size LxD(mm)
DPP209530	950x380 (4 dividers)
DPP212030	1200x380 (5 dividers)



Packaging Material Cutter C1	
Can be used to cut bubble wrap roll, kraft paper, corrugated paper, EPE foam packing roll	
Part NO.	Size LxD(mm)
DPP308001	M900 - Effective cutting length 690mm
DPP308002	M1200 - Effective cutting length 903mm
DPP308003	M1500 - Effective cutting length 1230mm



Packaging Material Cutter C2	
Can be used to cut bubble wrap roll, kraft paper, corrugated paper, EPE foam packing roll	
Part NO.	Size LxD(mm)
DPP408001	M700 - Effective cutting length 500mm

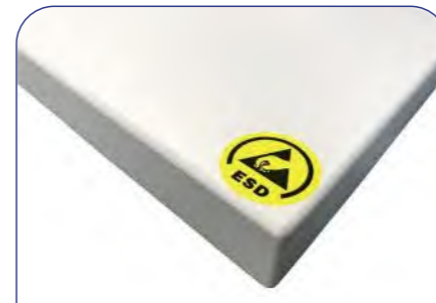

ESD (HPL) laminated top	
Color	Gray/ light blue
Sealing edge	Gray/yellow/black
Thickness	25mm

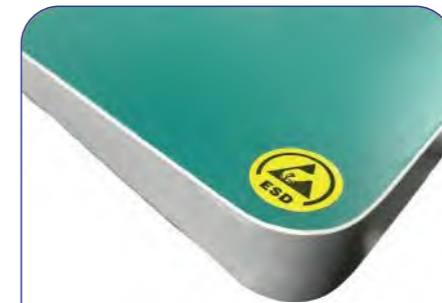

ESD rubber mat top	
Color	Gray/ green
Sealing edge	Gray/ black
Thickness	25mm



Melamine laminated top	
Color	Gray
Sealing edge	Gray
Thickness	18/25mm



ESD wearable top	
Color	Black
Material	Solid POM/ Bakelite
Thickness	15/20/25mm

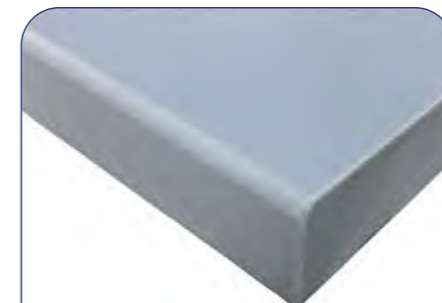

Epoxy resin top	
Color	White/gray/blue /green/black
Material	Solid epoxy resin
Thickness	18/20/25mm

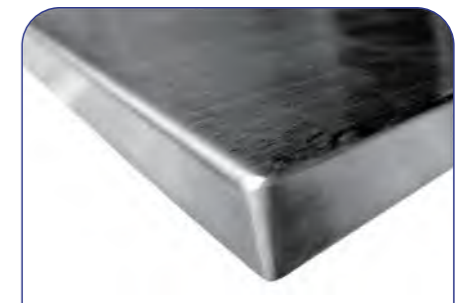

Stainless steel covered top	
Stainless steel	201/304
Steel thickness	0.8/1.0mm
Thickness	20/30/50mm



Bamboo wood top	
Color	Wooden
Sealing edge	None
Thickness	12/18/20/22/25/30mm



Solid beech wood top	
Color	Wooden
Sealing edge	None
Thickness	20/30/50mm



Plywood top	
Color	Wooden
Sealing edge	None
Thickness	30/50mm

- Can be extended and shortened: The available extendable length can be easily adjusted, and can be easily folded when not in use
- Small space occupied: The conveyor system is very compact when not in use.
- High efficiency and Flexible: can be easily moved and stored with casters. Can be connected together to extend the distance It can be bent at
- Arbitrary curved
- Self-tracking: The items conveyed on the flexible roller conveyor can follow the route of the flexible roller conveyor

Where use the expandable conveyor

- Places with limited venues and space, or limited storage space.
- The loading and unloading configuration is temporary and may change quickly.
- Need multiple loading or unloading points,
- Need to flexibly deal with fluctuations in different capacities.



Feature



Expandable structure



Height adjustable



Electrical motor drive



Movable wheels



>>>Expandable Gravity Skate Wheels Conveyor



Skate wheel--ABS skate wheel, using European imported material		
Telescopic slice--Bending structure, steel plate stamping parts, increase bearing capacity, bolt connection		
Frame--Carbon steel (Galvanized + electrophoresis)		
Castor--Universal brake caster, stable transportation		
Category	Unit	Specification
Open Length/section	mm	1000; 1250;1550 (Length can be customized)
Height adjustable	mm	450-650; 570-850; 750-1100; 900-1600; 1300-2000
Width- Loading bearing	Kg/m ²	500-26; 600-29; 800-32; (can be customized)
Width	mm	500mm; 600mm; 800mm; (can be customized)
Telescopic ratio		1:5

>>>Expandable Gravity Roller Conveyor



Roller--stainless steel + Galvanize +PVC		
Telescopic slice--steel plate stamping parts, increase bearing capacity, bolt connection, Surface electrophoresis treatment		
Frame--Carbon steel (Galvanized + electrophoresis)		
Castor--Universal brake caster, stable transportation		
Category	Unit	Specification
Open Length/section	m	1000; 1250;1550(Length can be customized)
Height adjustable	mm	450-650; 570-850; 750-1100; 900-1600; 1300-2000
Width- Loading bearing	Kg/m ²	500-37; 600-42; 800-48; (can be customized)
width	mm	500; 600; 800; 1000; 1200 (can be customized)
Telescopic ratio		1:4
Roller Dia	mm	38/50 mm (can be customized)

EXPANDABLE CONVEYOR

>>>O Ring Drive Roller Conveyor



Roller-- stainless steel + Galvanized		
2.Telescopic slice--steel plate stamping parts increase bearing capacity, bolt connection, surface electrophoretic treatment		
Frame--Carbon steel (galvanized +electrophoretic) stainless steel		
Castor--Universal belt brake caster, stable transportation		
Belt-- O-ring belt		
Category	Unit	Specification
Open Length/section	mm	1000; 1250;1550(Length can be customized)
Height adjustable	mm	400-550; 600-850; 750-1100
Loading bearing	Kg/m ²	25; 36; 50
width	mm	500; 600; 800; 1000; 1200 (Unit length can be customized)
Telescopic ratio		1:3
AC Motor		Power90/120W. Voltage 220V/380V
Electric control box		380V/220V Input; emergency switch; start/stop switch, forward and reverse switch; speed: 17-30meter /minute

>>>Multi-Belt Drive Conveyor



Roller-- stainless steel + Galvanized		
2.Telescopic slice--steel plate stamping parts increase bearing capacity, bolt connection, surface electrophoretic treatment		
Frame--Carbon steel (galvanized +electrophoretic) stainless steel		
Castor--Universal belt brake caster, stable transportation		
Belt-- Multi-wedge belt		
Category	Unit	Specification
Open Length/section	mm	1000; 1500;2000(Length can be customized)
Height adjustable	mm	400-550; 600-850; 750-1100
Loading bearing	Kg/m ²	30; 50; 80
width	mm	500; 600; 800; 1000; 1200 (Unit length can be customized)
Telescopic ratio		1:3
AC Motor		Power90/120W. Voltage 220V/380V
Electric control box		380V/220V Input; emergency switch; start/stop switch, forward and reverse switch; speed: 17-30meter /minute

EXPANDABLE CONVEYOR

>>>Synchronous Belt Power Conveyor



Roller-- stainless steel + Galvanized		
2.Telescopic slice--steel plate stamping parts increase bearing capacity, bolt connection, surface electrophoretic treatment		
Frame--Carbon steel (galvanized +electrophoretic) stainless steel		
Castor--Universal belt brake caster, stable transportation		
Belt-- Timing Belt		
Category	Unit	Specification
Open Length/section	mm	1000; 1500;2000(Length can be customized)
Height adjustable	mm	400-550; 600-850; 750-1100
Loading bearing	Kg/m ²	50; 80; 100
width	mm	500; 600; 800; 1000; 1200 (Unit length can be customized)
Telescopic ratio		1:3
AC Motor		Power90/120W. Voltage 220V/380V
Electric control box		380V/220V Input; emergency switch; start/stop switch, forward and reverse switch; speed: 17-30meter /minute

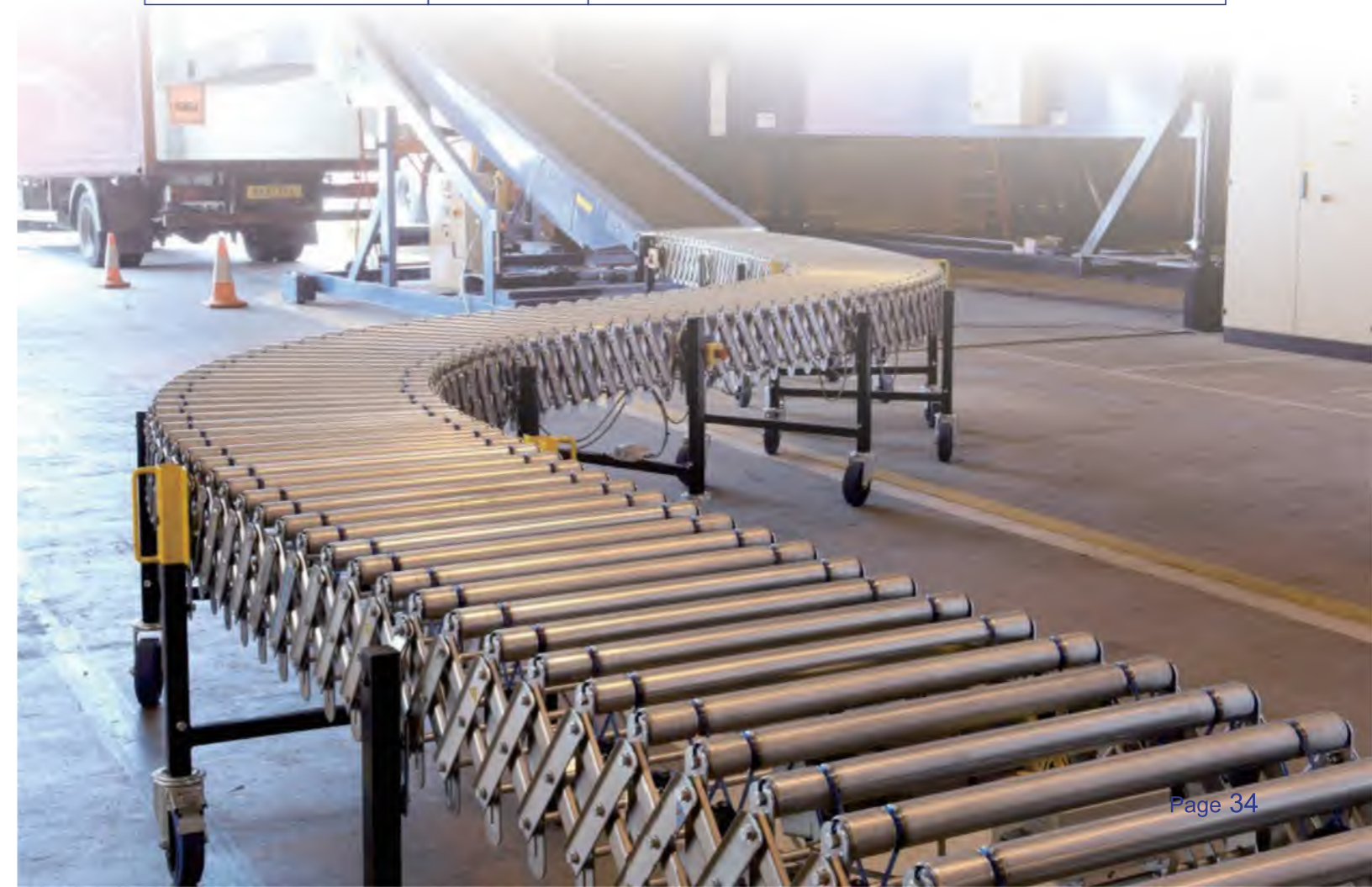

Features of the belt conveyor:

- Large conveying capacity, fast, stable operation, low noise, and continuous conveying of materials
- Simple structure, low cost, single operation, compact structure, easy maintenance and reliable operation
The transmission distance is long, not only the transmission length of a single machine is relatively long. But also multiple single machines can be stacked in series.
- Various control units and sensors can be integrated for easy program control and automatic operation.
It can be used for continuous or intermittent movement, and it can automatically stop and start to prevent falling.
- It is widely used in the transportation of parts for assembly in electronics, home appliances, food, automobiles, motorcycles and other industries.



Horizontal Transmission Belt Conveyor



Inclined Transmission Belt Conveyor



Curve Transmission Belt Conveyor



Telescopic Belt Conveyor



Integrated belt conveyor assembly line

Structure:	Integrate the belt conveyor part, the operating table part, the power supply part, the air source part, the lighting part and the storage part into one frame.
Advantage:	Compact structure, low cost, high cost performance.



Modular belt conveyor assembly line

Structure:	Composed of Detail's modular workbench and belt conveyor system
Advantage:	Each module works independently. Features parts that can be added or removed at will, high scalability, easy installation and relocation.



Multi-layer belt conveyor assembly line

Structure:	Formed by superimposing multiple layers of ultra-thin belt conveyors in the horizontal direction.
Advantage:	Materials can be transported in different directions or different types of materials can be transported at the same time. Improving the assembly efficiency of different materials



- Has a larger bearing capacity, can transport heavy objects.
- Additional functional designs can be obtained on the transport surface by the distance between the rollers.
- Suitable for transporting objects with flat and firm bottoms, such as prescribed, cases, skids, drums and more.
- The transfer surface is composed of individual rollers, which can be quickly and easily replaced.
- The function of the conveyor line can be changed by adding, removing and modifying rollers.

Driven System



Drum motor
small size, easy to install,
no need gearbox



Chain driven type
strong and sturdy, for heavy loads

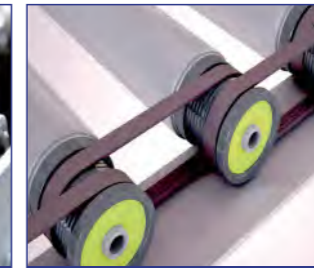

V-Belt driven type
Flexible connection, no noise,
for medium loads



O-Belt driven type
rollers are independently connected,
do not affect each other

Functional parts for roller conveyor



Turning section
The difference in speed
on either side of the conical roller to
rotate the object with it.



Steerable rollers
can change the direction
of delivery of goods



Ball transfer top
Universal ball allows the object
to rotate or change the
transfer direction manually.



Auto lifting & transfer
Lift objects off the roller
and transfer them to
another location.



Rotate transfer section
Changing the direction of
transport for heavy items

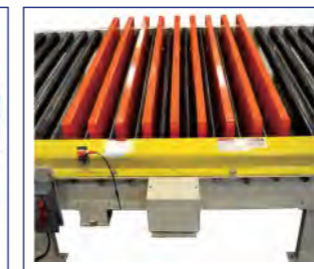

Lifting section
Fix the objects in a certain
position on the running roller



Lifting & rotating section
Simultaneous lifting and rotation,
so that objects are transported
at different heights and directions.



Foldable section
A section of the transport
line may be folded to
obtain a channel.



Telescopic conveyor



Flow confluence



Cycle roller conveyor



Functional rollers



Manual (Gravity) driven
roller conveyor



Motor driven roller conveyor



PLC controlled roller conveyor



Accumulating roller chain conveyor

- The conveyor is driven by the accumulation roller chain, with extensibility accessories such as conveyors, elevators, lifting and positioning stations, turning stations, stoppers, sensors, program control unit, etc. Allowed pallets can be positioned, stay, rotated, translated, lifted and lined up in different positions according to production requirements
- Widely used in electrical appliances, electronics, battery assembly and testing, automobile, motorcycle parts assembly and inspection, medical equipment production and other industries.



Assembly / testing Unit

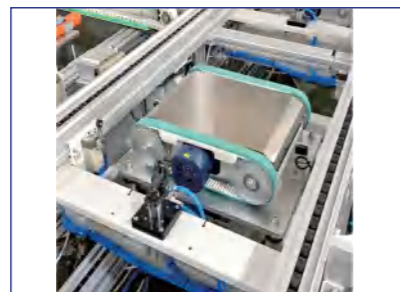

Lifting transmission Unit

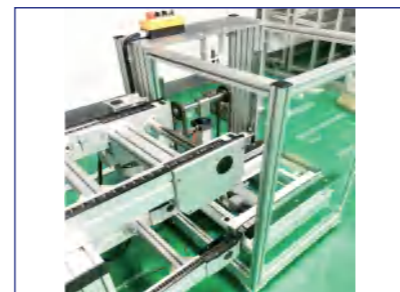

Tooling Lifting Unit

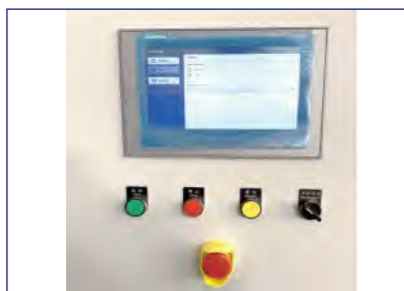

PLC - Programmable Logic Controller



Accumulating roller chain conveyor

O-shaped assembly conveyor line

The products move one by one with the conveying direction of the conveying line, the conveying route is fixed and simple, and the stations are set up on the conveying line, and the products are assembled, processed, tested and packaged in real time. The advantage is that the operation logic is simple and the cost is low. The disadvantage is that when the working efficiency of a particular station is slow, other workpieces will be blocked from entering subsequent stations, which will affect efficiency.



Double-layer roller chain conveyor line (Battery assembly)

The robot can place and remove heavy battery modules on the conveyor line. The conveyor line will send unassembled batteries to the assembly stations on the branch line according to the signal of each station, and send them back to the main line after completion. The advantage is that each station can work independently without being affected by other stations, and the work efficiency is high. The disadvantage is high cost.



Double-layer roller chain conveyor line (tablet/ laptop assembly & testing)

Multiple products assembled on the main conveyor can enter the branch line test station at the same time for testing. After the inspection, you can return to the main line and enter the next station.

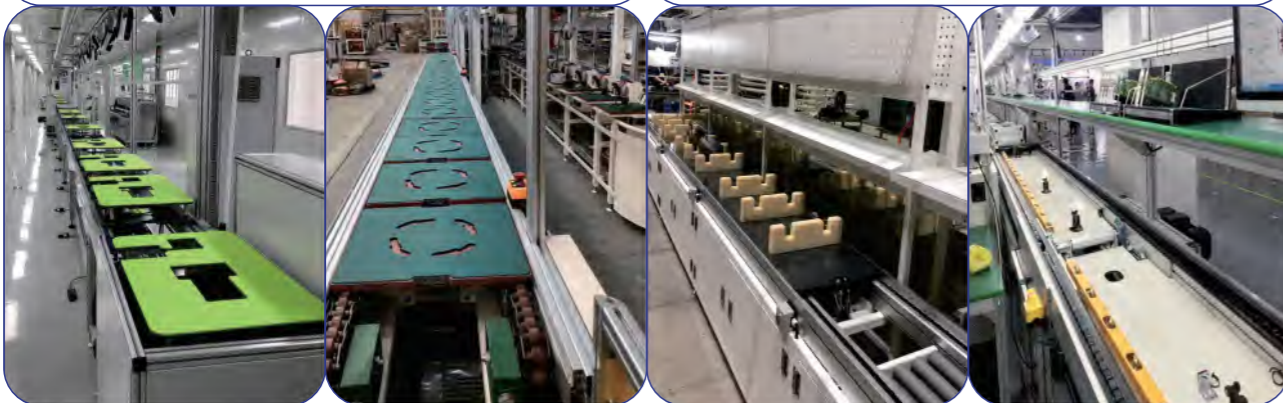
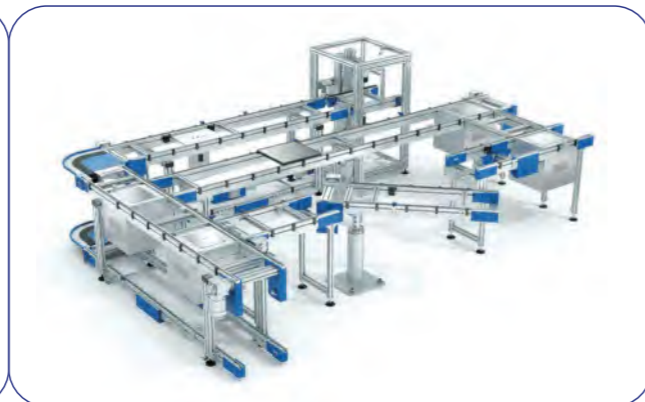

Accumulating free roller conveyor

Objects can be accumulated, and the friction between the staying product and the conveyor line is extremely low.



Flexible plastic chain conveyor

Low friction, high flexibility, suitable for transmission work in complex curves



Flexible modular plastic chain

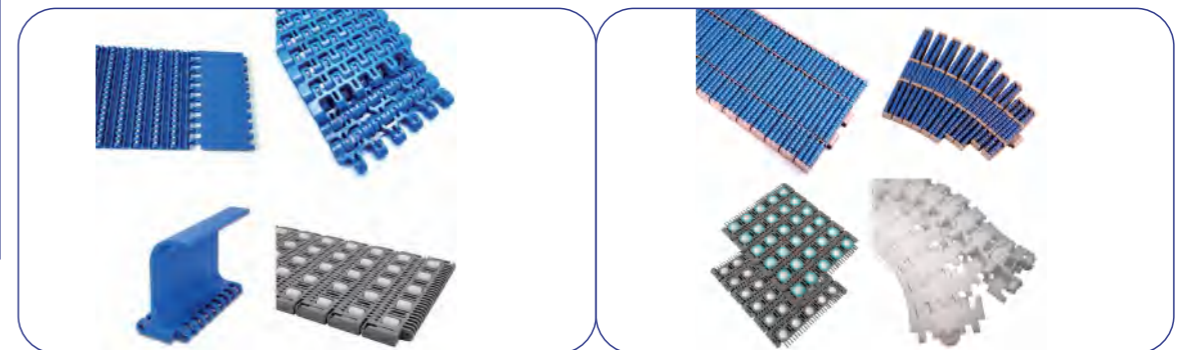

- Bearing Casters: Precision bearing casters, 2 fixed, 2 swivels, labor-saving, wear-resistant, slightly quiet, high-speed/high bearing capacity, front wheels are directional, rear wheels are universal, and steering is smooth and easy.
- Smooth and quiet: Great for use in noise sensitive environments such as library, hospital, office, hotel, school, ballroom, theatre, auditorium, laboratory, factory.
- Free push and pull: Anti-rust and durable, easy to hold, wide cargo baffle to prevent items from slipping, no need to bend and push and pull regardless of the height of the armrest, labor-saving and comfortable, can be used for a long time. Operation, protect the lumbar spine from damage, easy to carry.



Model No.	Size	Max Loading
150-DX-IV1	720×490mm	150kgs
300-DX-IV11	900×600mm	300kgs



Model No.	Size	Max Loading
150-T2-IV2	720×490mm	150kgs
300-T2-IV12	900×600mm	300kgs



Model No.	Size	Max Loading
150-T3-IV3	720×490mm	150kgs
300-T3-IV13	900×600mm	300kgs



Model No.	Size	Max Loading
150-T2-HL2-D-IV5	720×490mm	150kgs
300-T2-HL2-D-IV15	900×600mm	300kgs



Model No.	Size	Max Loading
150-T3-HL3-D-IV6	720×490mm	150kgs
300-T3-HL3-D-IV16	900×600mm	300kgs



Model No.	Size	Max Loading
300-AM1-IV7	900×600mm	300kg
400-AM1-IV17	1355×650mm	400kgs

ESD cart - RV series:

- ESD Laminate top, Metal frame are ESD powder painted
- ESD universal wheels, two wheels with fixing locks.
- Other customized sizes are available



ESD cart RV1
Size:600×500×750mm



ESD cart RV2
Size:600×500×750mm



ESD cart RV3
Size:600×500×750mm

ESD cart - TV series:

- All Steel cart with ESD powder painted
- ESD universal wheels, two wheels with fixing locks.
- Other customized sizes are available



ESD cart TV1
Size:650×450×750mm



ESD cart TV2
Size:650×450×1160mm



ESD cart TV3
Size:650×450×750mm

ESD cart - DV series: Multipurpose cart for circulation, storage and operation of materials, instruments and tools

- Upright frame allowed the exchange of the featured accessories.
- ESD universal wheels, two wheels with fixing locks.
- Loading capacity: 50kgs/shelf, 300kgs/cart
- Other customized sizes are available



ESD cart DV1
Size:840×650×720



ESD cart DV2
Size:780×650×1550



ESD cart DV4
Size:780×650×1550

ESD cart - PV series: Multipurpose cart for circulation, storage and operation of materials, instruments and tools

- Laminated countertops in larger sizes
- PV1 load-bearing 300 kg, height adjustable
- PV2 load-bearing 300 kg. • PV3 electric adjustable, load-bearing 100 kg



ESD cart PV1
Size: 750×600×770-1220mm



ESD cart PV2
Size: 935×600×1900mm



ESD cart PV3 (Motorized)
Size: 750×600×(590-890)mm

Packing cart - CV series:



Cutter rack CV1
CV1-1 single cutter
L870×D1000×H1430mm;
CV1-2 Double cutter
L870×1000×1670mm



Large Carton trolley CV2
L1080×D630×H1020mm





Carton trolley CV3
CV3-1: L1500×D700×H1740mm
CV3-2: L1500×D500×H1740mm



Model Number: NT-AT	Parameters	Features
	Speed: 30cm/s	Easy to operate
	Power: 200W	Multimode function
	Voltage: 100-120V / 200-300V	Cutter life exceeds 1000000 times
	Film Application: W4-8cm, D < 21cm	Warranty :24 months
	Size: W325×D477×H290mm	Customizable: Color, Logo, Packing
	NW: 12KG / GW: 16KG	Certificate: CE; PSE

Paper wrap system

Disposable paper wrap box	Model No.: B2-HP-G-50-80-80/IPW-K-30-17-135
	Material: high strength Kraft paper + white paper Length1: 80 meter/roll+135 meter/roll Width: 500mm+300mm (±5mm) Weight: 80gsm+17gsm (±2g) N.W: 4.0kg (±0.1kg) G.W: 5.2kg (±0.1kg) 580×260×180mm

Manual paper wrap Rack	Model No. : HP50-02
	Size: 60×40×20CM N.W: 3kg / G.W: 4kg Carton Size: 64×27×8cm

Powered feed paper wrap machine	Model No.: HP50-D2
	Power: 40W, 100-230V Speed: 35cm/s Size: 65×36×30CM N.W: 23kg / G.W: 25kg Carton Size: 80×50×26CM

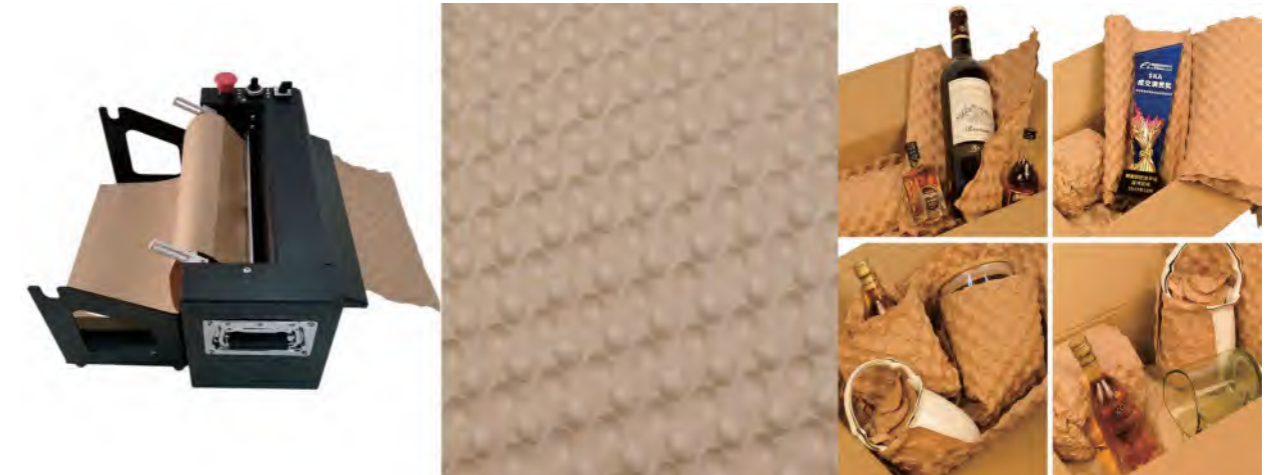



Model Number: Pb100		
	Speed: 10m/Min	
	Power: 100W	
	Voltage: 100-240V	
	Paper Bubble φ 12mm, Height 5mm	
	NW: 18KG / GW: 27KG	
	Size: W450×D200×H250mm	fan-folded paper : 80-160g, W≤300mm
	Pacing Size: W560×D320×H350mm	Roll paper: 80g, W≤300mm, φ≤28cm

Cardboard shredder



Model Number: HP-EX2		
	Speed: 3.5m/min	NW: 32KG / GW: 44KG
	Power: 180W	Easy to operate
	Voltage: 100-120V / 200-230V	Warranty :24 months
	Max Cutting width: 320mm	Customizable: Color, Logo
	Max Cutting thickness: 8mm	Certificate: CE
	Size: W490×D330×H300mm	
	Pacing Size: W500×D450×H350mm	

Manual Feed and Tear Paper Void Filler		
	Model Number	NP-S1
	Feature:	Easy clamp to the edge of bench
	Size:	35cm×47cm×60cm/35cm×47cm×80cm
	Weight:	N.W: 3.5kg / G.W: 5.5kg
	Packing Carton Size:	W550×D550×H180mm
	Certificate:	CE

Powered Feed and Cut Paper Void Filler		
	Model Number	PPO-1
	Speed:	12M/min
	Power:	120W
	Voltage:	100-120V /200-300V
	Paper Application:	380mm wide, fanfold paper
	Packing Carton Size:	W710×D450×H420mm
	Weight:	NW: 39KG / GW: 51KG
Certificate:	CE	

Powered Feed and Cut Paper Void Filler		
	Model Number	NP-EC
	Speed:	0.3M/s
	Power:	350W
	Voltage:	100-120V /200-300V
	Paper Application:	Unfolding 70CM – Folding 30CM
	Packing Carton Size:	W1360×D660×H750mm
	Weight:	NW: 78KG / GW: 110KG
	Certificate:	CE
Feature:	Automatically cuts Outfeed head can be tilted Digital touch screen control panel	

WIRE SHELF CART

Feature:

- Wide application: Work shop, maintenance station, kitchen, restaurant, home, etc.
- Easy to install: Quick and easy to install, no tools needed.
- Heavy duty structure: Sturdy metal construction, can withstand heavy objects.
- Fully adjustable: Each shelf can be adjusted by the clipping sleeves.
- Versatile Storage: Create additional space, easy to store things.

Specification:

- Main wire Dia : 6.0mm, wavy wires Dia: 4.5mm, Auxiliary wire Dia: 3.0mm , Column thickness: 1.2mm:
- Column (Posts) length: 600mm-2200mm
- Material: Alloy Steel (chromed); Stainless steel
- Weight capacity of 400 lbs (180 kg) per shelf (evenly distributed weight)

•Wire shelf size:

760×355mm	907×355mm	1060×355mm	1215×355mm	1360×355mm	1518×355mm	1822×355mm
760×457mm	907×457mm	1060×457mm	1215×457mm	1360×457mm	1518×457mm	1822×457mm
760×533mm	907×533mm	1060×533mm	1215×533mm	1360×533mm	1518×533mm	1822×533mm
760×609mm	907×609mm	1060×609mm	1215×609mm	1360×609mm	1518×609mm	1822×609mm

•SMD Reel wire shelf size:

Single reel wire	907*457mm	1215*457mm
Double reel wire	907*457mm	1215*457mm

•Other Details:



Model No.:MT-1
Size:W760×D355×H1040



Model No.:MT-2
Size:W760×D457×H1040



Model No.:MT-3
Size:W907×D457×H1040



Model No.:MT-4
Size:W907×D457×H1040



Model No.:MT-5
Size:W1518×D×533×H1700



Model No.:MT-6
Size:W1822×D609×H1700



Model No.:MT-7
Size:W907×D457×H1040



Model No.:MT-8
Size:W907×D457×H1040



Model No.:MT-9
Size:W1215×D457×H1700

Tool Cabinet



Model No.	GT-20	Model No.	GT-21	Model No.	GT-13
Outer size	900W×500D×1500H	Outer size	820W*820D*1520H mm	Outer size	900W×500D×1800H
Door	Aluminum Roller Door	Drawer	MB1-S 96pcs / MB1-L 24pcs	Drawer	Aluminum Roller Door
Shelf	4	Shelf		Shelf	7



Model No.	GT-1	Model No.	GT-4	Model No.	GT-7
Outer size	900W×500D×1800H	Outer size	900W×500D×1800H	Outer size	900W×500D×1800H
Drawer	100H×3	Door	Transparent glass door	Drawer	100H×3
Shelf	2 - adjustable	Shelf	4 - adjustable	Shelf	1 - adjustable

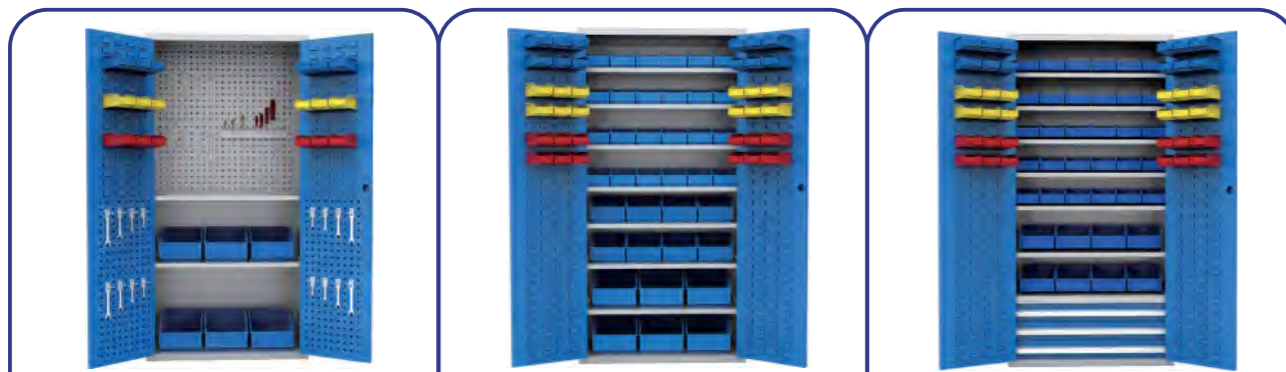

Model No.	GT-10	Model No.	GT-11	Model No.	GT-12
Outer size	900W×500D×1800H	Outer size	900W×500D×1800H	Outer size	900W×500D×1800H
Drawer		Door		Drawer	100H×3
Shelf	2 - adjustable	Shelf	7 - adjustable	Shelf	6 - adjustable

Classification Cabinet



Model No.	MD-1	Model No.	MD-2	Model No.	MD-3
Outer size	1000W×420D×1760H	Outer size	1050W×440D×1760H	Outer size	1000W×520D×1550H
Bin size	117W×400D×90H	Bin size	117W×400D×90H	Bin size	117W×500D×90H
Shelf	9pcs nonadjustable	Shelf	9pcs nonadjustable	Shelf	9pcs nonadjustable
Bin Qty	MB2 80PCS	Bin Qty	MB2 80PCS	Bin Qty	MB3 80PCS

Bins



Model No.	MB1	Model No.	MB2 ESD/MB2	Model No.	MB3 ESD/MB3
MB1-S	117W×300D×90H	External size	117W×400D×90H	External size	117W×500D×90H
MB1-L	234W×300D×140H	Inner size	94W×360D×80H	Inner size	94W×460D×80H
Divider	2(with hooks)	Divider	3(without hooks)	Divider	4 (with hooks)
Color	Blue	Color	Blue/Black(ESD)	Color	Blue/Black(ESD)



Model No.	HB1	Model No.	EB2 (ESD)	Model No.	GB1
HB1-S	103L×140D×75H mm	EB2-S	96W×160D×68H mm	GB1-M	195W×310D×135H mm
HB1-M	103L×190D×75H mm	EB2-M	130W×200D×89H mm	GB1-L	245W×380D×150H mm
HB1-L	141L×220D×125H mm	EB2-L	156W×237D×122H mm	Color	Blue
Color	Yellow, Red, Blue	Color	Black		



Feature:

- Humidity display range 1% ~ 60%RH, temperature display range -9.9℃ ~ 99.9℃.
- Display accuracy: temperature ±1℃; Humidity ±3%RH.
- The chemical hygroscopic agent can start to work after a power failure, and it can urgently replace the work of electronic dehumidifiers.
- Easy control; Temperature and humidity independent LED digital display.
- Optional nitrogen charging function
- Optional cabinet inner oxygen detection function



Application:

	<p>SMT and semiconductor packaging: IC (CSP, BGA, TQFP, TSOP) temperature dehumidification and low humidity preservation.</p>		<p>Chips and microelectronics: Dehumidification storage of multilayer substrate in printed circuit board before pressing and low humidity storage of style film and semi-cured film.</p>
	<p>The LED industry: Low humidity preservation and oxidation protection for materials and semi-finished products in precision manufacturing.</p>		<p>Photovoltaic and new energy industry: Low moisture preservation of ceramic substrates or ceramic condensers used in electronic machines.</p>
	<p>Optical instrument industry: Low humidity storage of bare IC and LSI wire rack before COB installation.</p>		<p>Medical device industry: Storage of test agents, test pieces, metal materials, powder materials and filter paper in the laboratory industry.</p>

Operational principle

The environmentally friendly moisture absorption device is equipped the crystal desiccant in the molecular sieve.

▲ Humidity absorbing

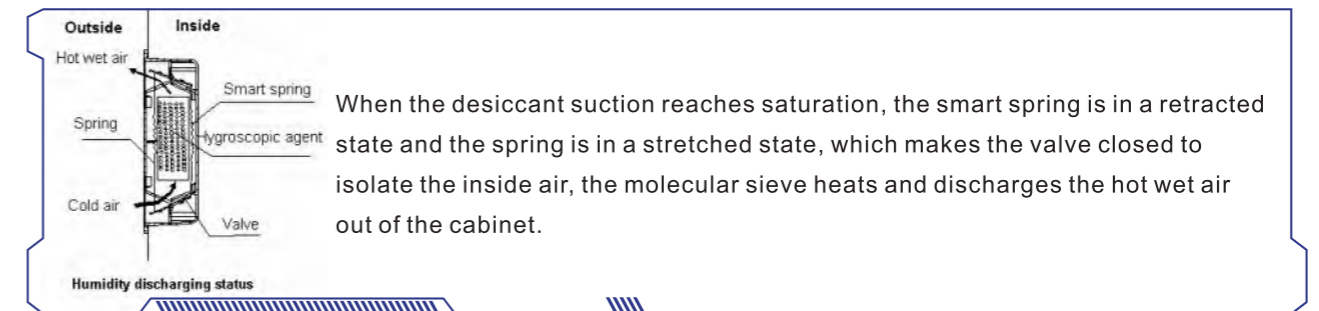
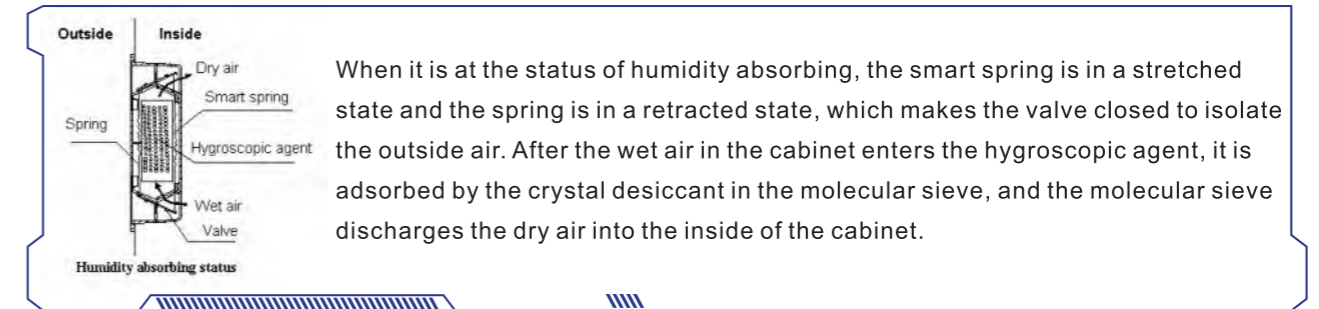

Volume 98L / Single-door

Outer size W*D*H 448*400*688mm / Inner size W*D*H 446*372*598mm

Model No.	Model No. (ESD)	Control range (RH)	Average Power(W)
DTS98D	DTS98FD	1%-3%(Automatic)	60
DTC98D	DTC98FD	1%-10%(Manual set)	60
DTB98D	DTB98FD	10%-20%(Manual set)	40
DTA98D	DTA98FD	20%-60%(Manual set)	20



Volume 160L / Single-door

Outer size W*D*H 448*450*1010mm / Inner size W*D*H 446*422*848mm

Model No.	Model No. (ESD)	Control range (RH)	Average Power(W)
DTS160D	DTS160FD	1%-3%(Automatic)	60
DTC160D	DTC160FD	1%-10%(Manual set)	60
DTB160D	DTB160FD	10%-20%(Manual set)	40
DTA160D	DTA160FD	20%-60%(Manual set)	20



Volume 240L / Two-door

Outer size W*D*H 598*400*1310mm / Inner size W*D*H 596*372*1148mm

Model No.	Model No. (ESD)	Control range (RH)	Average Power(W)
DTS240D	DTS240FD	1%-3%(Automatic)	60
DTC240D	DTC240FD	1%-10%(Manual set)	60
DTB240D	DTB240FD	10%-20%(Manual set)	40
DTA240D	DTA240FD	20%-60%(Manual set)	20



Volume 320L / Two-door

Outer size W*D*H 900*450*1010mm / Inner size W*D*H 898*422*848mm

Model No.	Model No. (ESD)	Control range (RH)	Average Power(W)
DTS320D	DTS320FD	1%-3%(Automatic)	60
DTC320D	DTC320FD	1%-10%(Manual set)	60
DTB320D	DTB320FD	10%-20%(Manual set)	40
DTA320D	DTA320FD	20%-60%(Manual set)	20



Volume 540L / Two-door

Outer size W*D*H 598*710*1465mm / Inner size W*D*H 596*682*1298mm

Model No.	Model No. (ESD)	Control range (RH)	Average Power(W)
DTS540D	DTS540FD	1%-3%(Automatic)	60
DTC540D	DTC540FD	1%-10%(Manual set)	60
DTB540D	DTB540FD	10%-20%(Manual set)	40
DTA540D	DTA540FD	20%-60%(Manual set)	20



Volume 718L / Three-door

Outer size W*D*H 598*710*1910mm / Inner size W*D*H 596*682*1723mm

Model No.	Model No. (ESD)	Control range (RH)	Average Power(W)
DTS718D	DTS718FD	1%-3%(Automatic)	60
DTC718D	DTC718FD	1%-10%(Manual set)	60
DTB718D	DTB718FD	10%-20%(Manual set)	40
DTA718D	DTA718FD	20%-60%(Manual set)	20



Volume 870L / Four-door

Outer size W*D*H 900*600*1890mm / Inner size W*D*H 898*572*1698mm

Model No.	Model No. (ESD)	Control range (RH)	Average Power(W)
DTS870D	DTS870FD	1%-3%(Automatic)	60
DTC870D	DTC870FD	1%-10%(Manual set)	60
DTB870D	DTB870FD	10%-20%(Manual set)	40
DTA870D	DTA870FD	20%-60%(Manual set)	20



Volume 1436L / Four-door / Six-door

Outer size W*D*H 900*600*1890mm / Inner size W*D*H 898*572*1698mm

Model No.	Model No. (ESD)	Control range (RH)	Average Power(W)
DTS1436D	DTS1436FD	1%-3%(Automatic)	60
DTC1436D	DTC1436FD	1%-10%(Manual set)	60
DTB1436D	DTB1436FD	10%-20%(Manual set)	40
DTA1436D	DTA1436FD	20%-60%(Manual set)	20



Constant temperature electric heating cabinet

Feature:

- The shell is made of cold rolled steel plate with ESD powder coated, the inner liner is made of high-quality stainless steel, the heater is made of high quality nickel-chrome.
- Thermal insulation materials are made of high temperature resistant glass fiber; Using nanomaterial door seal and thermal insulation material makes the performance more superior
- The temperature control system adopts microcomputer microcontroller. The system has the functions of temperature control, timing and overtemperature alarm.
- Digital display screen, the value is accurate and intuitive, setting and adjustment by touchable buttons.
- Reasonable air duct and circulation system make a better temperature uniformity.
- The height and number of the shelves can be adjusted to the user's requirements
- The door is equipped with a large viewing window to facilitate user observation



Model No.	Input Power	Power	temperature	Temperature fluctuations	Temperature uniformity	Inner size W*D*H mm	Outer size W*D*H mm
DCTG-9020	220V, 50HZ	700W	+10-250°C	±0.5°C	±3%	300x300x270	580x480x440
DCTG-9050		1050W				420x350x350	700x530x520
DCTG-9120		1750W				550x350x550	860x530x730
DCTG-9200		2100W				600x525x600	910x725x780
DCTG-9020A		800W	+10-300°C	±0.5°C	±3%	300x300x270	580x480x440
DCTG-9050A		1200W				420x350x350	700x530x520
DCTG-9120A		1900W				550x350x550	860x530x730
DCTG-9200A		2300W				600x525x600	910x725x780
VCTG-9030	220V, 50HZ	800W	+10-250°C	±0.5°C	±3%	340x320x320	490x500x560
VCTG-9070		1600W				400x350x500	550x530x760
VCTG-9140		1900W				550x450x550	600x650x810
VCTG-9240		2400W				500x600x750	650x800x1010
VCTG-9030A		1200W	+10-300°C	±0.5°C	±3%	340x320x320	490x500x560
VCTG-9070A		1900W				400x350x500	550x530x760
VCTG-9140A		2300W				550x450x550	600x650x810
VCTG-9240A		2800W				500x600x750	650x800x1010
VCTG-9420	380V, 50HZ	3600W	+10-250°C	±0.5°C	±3%	600x550x1300	750x750x1560
VCTG-9620		4100W				800x600x1300	950x800x1560
VCTG-9920		5300W				1000x600x1600	1150x800x1860
VCTG-9420A		4100W	+10-300°C	±0.5°C	±3%	600x550x1300	750x750x1560
VCTG-9620A		4700W				800x600x1300	950x800x1560
VCTG-9920A		6200W				1000x600x1600	1150x800x1860

Miniature nitrogen making machine

Model No.: DTNG1815
 Outer size(W*D*H):350*500*751mm
 Nitrogen production : 13L /min (Over 99% purity)
 Nitrogen concentration : 98% - 99.9%
 The environment temperature : 0 ~ 50°C
 Input compressed air : The temperature≤20°C. pressure 6~8bar
 Display: LED
 Input power : 220V 50Hz/60Hz
 Standby power : ≤10W
 Max Power : ≤40W
 Color: gray / black
 Requirements: Users have pipe compressed air (after freeze drying treatment is better)



Mainly used for storage inflammable liquid and some dangerous chemicals.

Safely contains hazardous chemicals reducing the risk of fire

Units come fully assembled and ready for use

Electrical ground on bottom right hand side to aid in the elimination of an electrostatic discharge

Improved security with recessed lockable paddle latch and 3 point locking system



Model No.	FD-1	Model No.	FD-2	Model No.	FD-3
Outer size	430W×430D×560H	Outer size	590W×460D×890H	Outer size	1090W×460D×1120H
Inner size	350W×350D×460H	Bin size	510W×380D×750H	Bin size	1010W×380D×990H
Volume	4gal - 15L	Volume	12gal - 45L	Volume	30gal - 113L
Shelf	1	Shelf	1	Shelf	1



Model No.	FD-4	Model No.	FD-5	Model No.	FD-6
Outer size	860W×860D×1650H	Outer size	1090W×860D×1650H	Outer size	1500W×860D×1650H
Inner size	780W×780D×1520H	Bin size	1010W×780D×1520H	Bin size	1420W×780D×1520H
Volume	60gal - 225L	Volume	90gal - 337L	Volume	110gal - 412L
Shelf	2	Shelf	2	Shelf	1

ESD shelves

- Shelves are made of cold rolled steel sheet, ESD powder coated
- Quick installation design without bolts
- The height of the shelves can be adjusted according to the pitch of 50 mm per section.
- Load-bearing: 100 kg per layer for light duty, 300 kg per layer for medium duty.

Part No.	Loading/layer	Size(mm)
DTHR01252	100kgs	W1200×D500×H2000
DTHR01552	100kgs	W1500×D500×H2000
DTHR01562	100kgs	W1500×D600×H2000
DTHR11252	300kgs	W1200×D500×H2000
DTHR11552	300kgs	W1500×D500×H2000
DTHR11562	300kgs	W1500×D600×H2000
DTHR11852	300kgs	W1800×D500×H2000
DTHR11862	300kgs	W1800×D600×H2000



FIFO shelves

- The goods slide on the rollers by their own weight
- Easy access, first in first out, suitable for assembly lines and distribution centers

Part No.	Loading/layer	Size(mm)
DTHF15102	100kgs	W1500×D1000×H2000
DTHF15122	200kgs	W1500×D1200×H2000
DTHF18102	100kgs	W1800×D1000×H2000
DTHF18122	200kgs	W1800×D1200×H2000
DTHF20102	100kgs	W2000×D1000×H2000
DTHF20122	200kgs	W2000×D1200×H2000
DTHF24102	100kgs	W2400×D1000×H2000
DTHF24122	200kgs	W2400×D1200×H2000



Heavy duty shelves

- Shelves are made of cold rolled steel sheet
- Quick installation design without bolts
- The height of the shelves can be adjusted according to the pitch of 50 mm per section.
- Load-bearing: 500~1000kg per layer

Part No.	Loading/layer	Size(mm)
DTHH51512	500kgs	W1500×D1000×H2000
DTHH11512	1000kgs	W1500×D1000×H2000
DTHH52012	500kgs	W2000×D1000×H2000
DTHH12012	1000kgs	W2000×D1000×H2000
DTHH52512	500kgs	W2500×D1000×H2000
DTHH12512	1000kgs	W2500×D1000×H2000
DTHH53012	500kgs	W3000×D1000×H2000
DTHH13012	1000kgs	W3000×D1000×H2000



Heavy duty pallet shelves

- Shelves are made of cold rolled steel sheet
- Max length 3.6m per section; Depth & Height are customized
- The height of the shelves can be adjusted according to the pitch of 75 mm per section.
- Load-bearing: 1000~4000kg per layer

Part No.	Loading/layer	Size(mm)
DTHP12713	1000kgs	W2700×D1000×H3000
DTHP22713	2000kgs	W2700×D1000×H3000
DTHP32713	3000kgs	W2700×D1000×H3000
DTHP42713	4000kgs	W2700×D1000×H3000



Wire Organizer shelves



ESD Aging test shelves



ESD table mat

- The upper surface layer is antistatic layer, the bottom layer is black conductive layer .thickness is 1 :1 .
- It features , oil resistance, acid and alkali resistance, high elasticity, smooth surface, etc.

Material	Nitrile-butadiene rubber
Specification	L-10m, W-0.8/1.0/1.2m, T=2/3mm
Upper layer Resistance	$10^7-10^9 \Omega$
Bottom layer Resistance	$\leq 10^6 \Omega$
Volume Resistance	$10^8-10^9 \Omega$

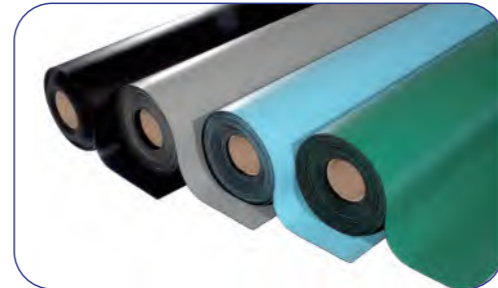

ESD foamed mat

- The interior of the product has a network structure and uniform resistance distribution, and has the functions of wear resistance, acid and alkali resistance, high elasticity, high toughness, anti-aging, radiation protection, shock resistance, fatigue resistance.

Material	PVC
Specification	L-10m, W-1.3m, T=3.5mm
Resistance	$10^7-10^9 \Omega$
Flame retardant property	V-0 (< 5s)
Abrasion resistance property	$\geq 1000\text{rpm}$

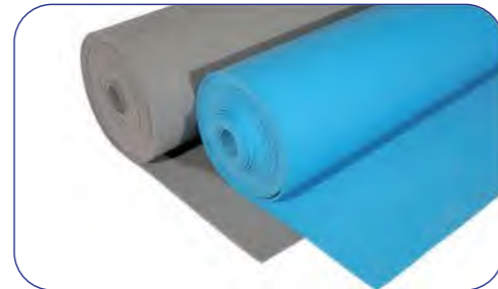

ESD fire-resistant mat

- It consists of an upper ESD anti-skid layer, an intermediate ESD wear-resistant layer, and a bottom conductive layer.
- It features oil resistance, acid and alkali resistance, fire resistance, flame resistance, smooth surface, etc.

Material	
Specification	L-10m, W-0.8/1.0/1.2m, T=2mm
Upper/ intermediate layer Resistance	$10^7-10^9 \Omega$
Bottom layer Resistance	$10^4-10^6 \Omega$
Volume Resistance	$10^8-10^9 \Omega$
Flame retardant property	V-0 (< 5s)
Abrasion resistance property	$\geq 1000\text{rpm}$

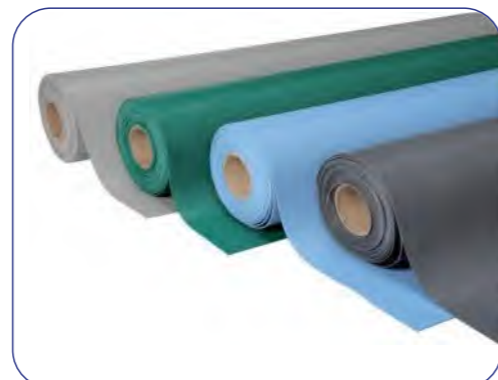

ESD anti-fatigue floor mat

- It is suitable for workplaces that need to stand for a long time, relieve human fatigue and anti-static requirements, and effectively buffer the pressure on the feet and relieve fatigue.
- The upper layer is ESD PVC/rubber, the middle layer is EPDM (or urethane resin, PVC, EVA) foam, and the bottom layer is conductive rubber.

Material	Nitrile-butadiene rubber
Specification	600×900/600×1200/900×1200mm
Color	Main (Black, Green, Gray); Edge (Yellow)
Volume Resistance	$10^5 \Omega-10^9 \Omega$
Custom size	depth 600/900/1200mm; length 2000mm

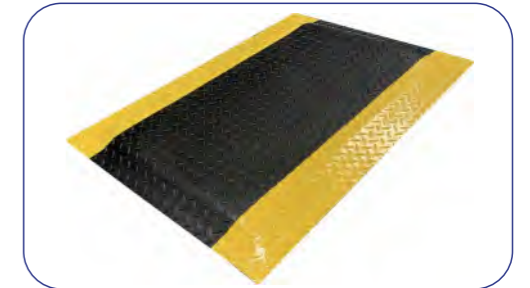

ESD PVC Plastic Tile

Size:	L*W=600*600/610*610/900*900mm, T=2.0/3.0mm				
System resistance	Decay time	Rate of size change at heating	Friction voltage	Amount of wear	Flame retardant performance
$10^6-10^9 \Omega$	1000-100V 2s	$\leq 0.20\%$	<100V	$\leq 0.02\text{g}/\text{cm}^2$	V-0 (<10s)

Anti-corrosion					
HCL	Alcohol	Acetone	NaOH Aqueous solution	Gasoline	Normal Detergent
OK	OK	OK	OK	OK	OK

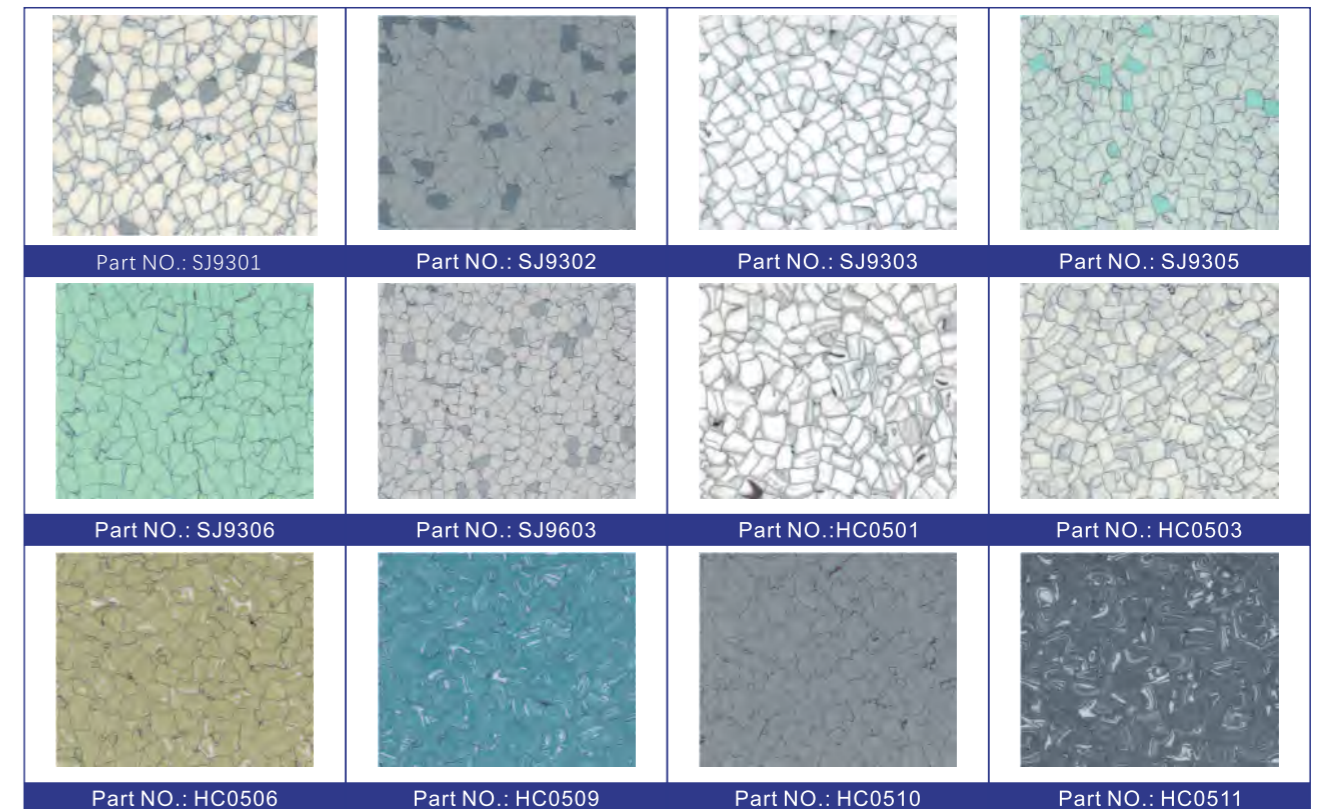

- The fume purifier system can be mounted on a bench.
- Contaminated air can be cleaned and recycled back to the workshop without external exhaust.
- Modular filter packs can be easily and quickly replaced.



Wave soldering fume purifier

			
Model No.:	E200D	FC210D	FC300I
Net weight	12kgs	18kgs	35Kg
External size	290×370×460mm	290×370×460mm	330×370×600mm
Air flow	150m³/h	150m³/h	300m³/h
Rated power	135W	135W	300W
Input Voltage	220V	220V	220V
Noise	55dB	50dB	55dB
Filter blockage alarm	Yes	Yes	Yes
Flow adjustable	No	Yes	Yes
Filtration accuracy	0.3µm	0.3µm	0.3µm
Filtration efficiency	99.997%	99.997%	99.997%
Extraction arms	2	2	2/3

			
Model No.:	PF800	PF1600D	DPF4000D
Net weight	100Kg	160Kg	350Kg
External size	600×750×1170mm	680×860×1240mm	1350×950×1950mm
Air flow	800m³/h	1400m³/h	4000m³/h
Rated power	630W	1.15KW	4.0KW
Input Voltage	220V	220V	380V
Noise	55dB	55dB	62dB
Filter blockage alarm	Yes	Yes	Yes
Flow adjustable	No	No	Yes
Filtration accuracy	0.3µm	0.3µm	0.3µm
Filtration efficiency	99.997%	99.997%	99.997%
Fume inlet pipe (Inner diameter)	Φ150mm	Φ150mm	Φ300mm
Applicable to (work station qty)	6-10	10-18	20-30

Task Chair

- Antistatic polyurethane work chair, for research, designing and manufacture factory, beautiful and durable
- Ergonomic design, comfortable, anti fatigued, durable, anti-static: $10^6 - 10^9 \Omega$
- All chairs could be equipped with high rod, metal foot ring, handrails, chair glid, castor wheels and aluminum alloy metal wheel.
ESD Polyurethane chair, ESD Fabric chair, ESD Vinyl Chair.



ESD Polyurethane Chair



		
ESD Chair K1L Size: Seat 390×410mm; Back 280×380mm; Seat height 440-590mm R320mm Chrome base;	ESD Chair K2 Size: Seat 430×460mm; Back 305×410mm; Seat height 555-755mm R320mm Chrome base; D450mm Foot ring	ESD Chair K2L Size: Seat 430×460mm; Back 305×410mm; Seat height 440-590mm R320mm Chrome base;
		
ESD Chair K3 Size: Seat 440×410mm; Back 370×390mm; Seat height 555-755mm R320mm Chrome base; D450mm Foot ring	ESD Chair K3L Size: Seat 440×410mm; Back 370×390mm; Seat height 440-590mm R320mm Chrome base;	ESD Chair K4L Size: Seat 430×455mm; Back 300×415mm; Seat height 440-590mm R320mm Chrome base;
		
ESD Chair K5L Size: Seat 410×420mm; Back 275×380mm; Seat height 440-590mm R320mm Chrome base	ESD Chair K6L Size: Seat 450×480mm; Back 300×440mm; Seat height 440-590mm R320mm Chrome base	ESD Chair K7H Size: Seat 434×442mm; Back 337×377mm; Seat height 555-755mm R320mm Chrome base; D450mm Foot ring; Adjustable hand rail



ESD Stool

		
ESD Chair M1	ESD Chair M2	ESD Chair M3
Size: Seat 350×320mm; Seat height 400-530mm	Size: Seat 340×340mm; Back 245mm; Seat height 400-530mm	Size: Seat 350×340mm; Seat height 400-530mm
R280mm Steel tube base;	R280mm Steel tube base;	R280mm Steel tube base;
		
ESD Chair M4	ESD Chair M5	ESD Chair M6
Size: Seat 410×330mm; Seat height 420-560mm	Size: Seat D340mm; Seat height 600-780mm	Size: Seat D320; Seat height 420-560mm
R280mm Steel tube base;	R280mm Steel tube base; D400mm Foot ring	R280mm Steel tube base;
		
ESD Chair M7	Stainless steel stool M8	ESD Chair M9
Size: Seat D330mm; Seat height 420-560mm	Size: Seat D320; Seat height 420-560mm	Size: Seat D320mm; Back 305×130mm; Seat height 420-560mm
R280mm Steel tube base;	R280mm Steel tube base;	R280mm Steel tube base;

Office Chair



		
Office Chair P14	Office Chair P15	Office Chair P16
Size: W640×D510×H980-1080mm	Size: W600×D500×H980-1240mm	Size: W620×D510×H1150-1250mm
D580mm Nylon Base	D580mm Nylon Base	D610mm chromed Base, Adjustable Hand-rail, Adjustable waist support, Adjustable back angle
		
Office Chair P17	Office Chair P18	Office Chair P19
Size: W655×D500×H1150-1250mm	Size: W645×D500×H1150-1250mm	Size: W640×D500×H1060-1160mm
D600mm Aluminum Base, Adjustable Hand-rail, PU sponge, Double adjustable back,	D600mm Aluminum Base, Adjustable Hand-rail, PU sponge, Double adjustable back, Adjustable waist support,	D640mm Aluminum Base, Multi-Adjustable Hand-rail, PU sponge, Double adjustable back, Ergonomic waist support,

			
AP-DC2453	AP-DC2451	AP-AC2459	
Input voltage	DC 12V	DC 15V	AC 220V /50Hz or 110V/60 Hz
Power	5.5W	9W	50W/250W
Operating Voltage	±DC4000→DC7000V	±DC4000→DC7000V	AC3500V
Emitter electrode	Tungsten alloy	Tungsten alloy	Stainless steel
Discharge range	450*300mm(L*W)	750*300mm(L*W)	600*1200mm (W*L)
Discharge speed	≤1.5s	≤2s	≤ 2s
Ion balance	-15V - +15V	≤ ± 10V	≤ ±10V
Air volume	≤48.2CFM	≤89.1CFM	70~120CFM
Audio noise	≤38.9db	≤43db	≤ 50-55db
ozone density	≤0.05ppm	≤0.05ppm	≤ 0.03 ppm
Dimensions	113*54*129mm(L*W*H)	180*60*201.5mm(L*W*H)	454*216*185mm(L*W*H)
Adapter power	INPUT: AC110-240V 50/60Hz; OUTPUT: DC12V 1000mA	INPUT: AC110-240V 50/60Hz; OUTPUT: DC15V 2000mA	
Gross weight	600g	1980g	8200g

			
AP-DC2452-60C	AP-DC2452-80C	AP-DC2452-100C	
Input voltage	AC 220V /50Hz or 110V/60 Hz	AC 220V /50Hz or 110V/60 Hz	AC 220V /50Hz or 110V/60 Hz
Power	<15W	<18W	<25W
Operating Voltage	±DC4000→DC7000V	±DC4000→DC7000V	±DC4000→DC7000V
Emitter electrode	Tungsten alloy	Tungsten alloy	Tungsten alloy
Discharge range	600*300*750mm (W*L*H)	800*300*750mm (W*L)	1020*300*750mm (W*L)
Discharge speed	≤ 3s (450mm testing center from the air outlet)		
Ion balance	≤ ± 10V (150mm from the front of the air outlet)		
Air volume	≤ 2*89.1CFM	≤ 3*89.1CFM	≤4*89.1CFM
Audio noise	≤55db	≤ 60db	≤65db
ozone density	≤0.05ppm (150mm away from the air outlet)		
Dimensions	640*175*118mm(L*W*H)	840*175*118mm(L*W*H)	1040*175*118mm(L*W*H)
Gross weight	3650g	4200g	5150g

Comprehensive test mode can test the wearing status of wrist straps and anti-static shoes simultaneously; individual mode can set to test the wearing status of wrist straps, foot rings separately, and you can choose to test single-wire or dual-wire wrist straps.

- Measuring range: 100KΩ-1GΩ, range adjustable.
- The access control system controls the signal, controlling the in-and out personnel to meet the electrostatic protection requirements.
- Micro current to test, accurate data, stable test.
- Low voltage alarm: when the battery of the tester is low, the alarm indicator will flash.
- Produced according to GJB3007-97, SJ/T10694-2006 and ANSI/ESD-S20.20-2021

		
Model No.:	492E	492GNA 492GXA
Power supply	9V Battery / Accoupling adapter DC8-12V	
Contact switch output	voltage	±400V (Max) (Peak value.DC or AC)
	switch	130mA(Max) ; 30Ω
Accuracy	±10%	
Ambient environment	Indoor use, humidity 40% -60% RH	
Dimension	100mm*162mm*39mm	
weight	8.6KG	
LCD	NO	YES YES
Touch panel	NO	YES YES
Computer connectable	NO	NO YES

ACL 380 Resistivity Meter

	Accuracy	± 0.25 decade in the dissipative range
	Power supply	9 volt alkaline battery
	Test Voltage	10 volts at values less than 10 ⁶
		100 volts at values of 10 ⁶ and greater
	Resistivity Limits	10 ³ - 10 ¹¹ ohms per square
		Resistance Limits (when using external probes) 103 - 1012 ohms
LED Colors	Green 10 ³ - 10 ⁵ /Yellow 3 x 10 ⁵ - 10 ⁹ /Orange 3 x 10 ⁹ - 10 ¹⁰ /Red 10 ¹¹ - 10 ¹²	

ACL 350 Digital Static Locator

3-1/2 digit LCD, automatically displaying measured voltage

	Polarity	Automatic, positive implied, negative polarity indication
	Zero	Semi-automatic "Push to Zero" feature
	Response	Display updates three times per second
	Range	0 ± 80,000 volts
	Overall Accuracy	Better than ± 10%
	Battery SavRTM Timeout	After 90 seconds meter automatically shut off
	Power	One (1) standard 9-volt battery, PROCELL, Eveready #1222(NEDA 1604, JIS 006P, IEC 6F22)
	Dimensions	4.2" x 2.4" x 0.9"
	Weight	5 oz. (142 g)

ACL 800 Digital Megohmmeter

Measures resistivity, temperature, and humidity

	Resistivity range	10 ³ - 10 ¹² ohms/square
	Resistance range	10 ³ - 10 ¹² ohms
	Relative humidity range	10% to 90% RH
	Temperature range	32°F to 100°F (0°C - 37.7°C)
	Test voltage range	10v/100v
	Accuracy	10 ³ - 10 ⁸ ohms: 10%/10 ⁹ - 10 ¹⁰ ohms: 15%/10 ¹¹ - 10 ¹² ohms: 25% Alphanumeric LCD scale shows actual values

PC27-7H Digital Megohm meter

	Test voltage	100/500V
	Test Range	20000M
	Resolution	1K
	0-100M Accuracy	±1%
	100-2000M Accuracy	±2%
	Open-circuit voltage error	≤±5%
	Size	168 x 84 x 42mm

	Model	203H
	Station power	90 W
	Output voltage (heater)	36 V , 400kHz
	Station supply voltage	220V AC
	Temperature range	50 °C – 600 °C
	Soldering tip	200 Series
	Temperature control	digital, with push-buttons
	Kind of display used	3-digit LED
	Heating element	electromagnetic element
	Tip-to-ground potential	< 2 mV
	Tip-to-ground resistance	< 2 Ω
	Dimensions,	130 x 200 x 100 mm
	Weight	About 3.2kg

	Model	205
	Station power	150 W
	Output voltage (heater)	36 V , 400kHz
	Station supply voltage	220V AC
	Temperature range	50 °C – 600 °C
	Soldering tip	500 Series
	Temperature control	digital, with push-buttons
	Kind of display used	3-digit LED
	Heating element	electromagnetic element
	Tip-to-ground potential	< 2 mV
	Tip-to-ground resistance	< 2 Ω
Dimensions,	130 x 200 x 100 mm	
Weight	About 4.6kg	

	Model	TS8
	Power	150W
	Heating principle	Resistance type
	Operating voltage	220V AC
	Temperature range	100~450 °C
	Tip to ground resistance	<2Ω
	Tip to ground potential	<2mV
	Soldering iron model	TSS80A
	Heater	Integrated type
	Soldering tip	TSS08 series
	Outer dimensions	137 x 168 x 114(mm)
Weight	About 2.9kg	

			
Model No:	TS1100	TS1200D	TS2400
Power	90W	120W	400W
Heating principle	Resistance-type	Resistance-type	Resistance-type
Operating voltage	110V/220V AC	110V/220V AC	220V AC
Temperature range	200~420°C	200~420°C	100~500°C
Temperature stability	±2°C	±2°C	±2°C
Tip to ground resistance	<2Ω	<2Ω	<2Ω
Tip to ground potential	<2mV	<2mV	<2mV
Handle model	TSS30A	TSS30B	TSS400
Heating element	TSS10A		H206E
Soldering tip	960series	TSS02series	504series
Soldering tip/ heating element	Split type	Integrated	Split type
Outer dimensions	113 x 150 x 92mm	137 x 168 x 114mm	190 x 190 x 134mm
Weight	About 2.3kg	About 2.8kg	About 2.6kg
Computer control		No	Yes

Digital Hot Air Rework Station

	Model	959D
	Power	580W
	Display type	LCD
	Operating voltage	220V AC
	Temperature range	100~500°C
	Tip to ground resistance	<2Ω
	Tip to ground potential	<2mV
	Air volume	1~100 Class
	Air flow	40L/min(Max)
	Three-channel storage	yes
	Outer dimensions	110 x 180 x 151mm
	Weight	About 1,6kg

Use on the perforated panel

Single hook	Part No.	Specification	Double hook	Part No.	Specification	Wire hook	Part No.	Specification
	HK001001	25mm		HK002001	25mm		HK003001	100mm
	HK001002	50mm		HK002002	50mm		HK003002	150mm
	HK001003	75mm		HK002003	75mm		HK003003	200mm
	HK001004	100mm		HK002004	100mm			
	HK001005	150mm		HK002005	150mm			
	HK001006	200mm		HK002006	200mm			
Round hook	Part No.	Specification	Clamp hook	Part No.	Specification	Six-rod hook	Part No.	Specification
	HK004001	40mm		HK005001	150mm		HK006001	235×145mm
	HK004002	60mm						
	HK004003	80mm						
U hook	Part No.	Specification	Wrench sleeve hook	Part No.	Specification	Wrench sleeve rack	Part No.	Specification
	HK007001	75×35mm		HK008001	30×45mm		HK009001	195×27×44mm
	HK007002	25×55mm						
	HK007003	25×35mm						
Hex key holder	Part No.	Specification	Wrench rack	Part No.	Specification	Screw driver rack	Part No.	Specification
	HK010001	100×90×12		HK011001	145×135×60mm		HK012001	375×30×55mm
Drill bit rack	Part No.	Specification	Bin hook	Part No.	Specification	Magnetic Hooks	Part No.	Specification
	HK013001	390×26×60mm		HK014001	95×30mm		HK015001	400×50mm
rod hook	Part No.	Specification	Electric screwdriver rack	Part No.	Specification	Bottle rack	Part No.	Specification
	HK016001	380×55mm		HK017001	160×60×60mm		HK018001	340×80×80mm D=70mm
Fenced shelf	Part No.	Specification	Flat shelf	Part No.	Specification	Angle grinder rack	Part No.	Specification
	HK019001	160×160×60mm		HK020001	220×110mm		HK021001	190×35×118mm
	HK019002	210×100×60mm		HK020002	360×110mm			D120mm
	HK019003	400×100×60mm		HK020003	440×110mm			
	Part No.	Specification	Saw hook	Part No.	Specification	Pot	Part No.	Specification
	HK022001	30×60mm		HK023001	75×40mm		HK024001	W75×H120mm
	HK022002	40×100mm						